

# DOWNERS GROVE GRADE SCHOOL DISTRICT 58 PIERCE DOWNER PLAYGROUND IMPROVEMENTS - PHASE II

1436 GRANT STREET  
DOWNERS GROVE, IL 60515

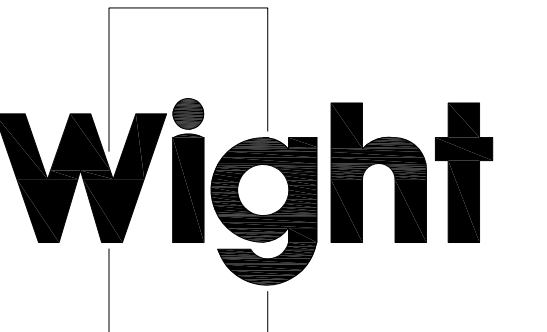

DOWNERS GROVE  
SCHOOL DISTRICT 58



Wight & Company  
wightco.com

2500 North Frontage Road  
Darien, IL 60561

P 630.969.7000  
F 630.969.7979

## PROJECT TEAM

### CLIENT:

DOWNERS GROVE GRADE SD 58  
1860 63RD STREET  
DOWNERS GROVE, IL 60516  
PHONE: (630)719-5858  
CONTACT: KEVIN BARTO

### CIVIL ENGINEER:

WIGHT & COMPANY  
2500 NORTH FRONTAGE ROAD  
DARIEN, IL 60561  
PHONE: (630)969-7000  
FAX: (630)969-7979  
CONTACT: KYLE BUCK  
Design Firm Registration #184-000451

### LANDSCAPE ARCHITECT:

WIGHT & COMPANY  
2500 NORTH FRONTAGE ROAD  
DARIEN, IL 60561  
PHONE: (630)969-7000  
FAX: (630)969-7979  
CONTACT: PATTY KING  
Design Firm Registration #184-000451

## LOCATION MAP

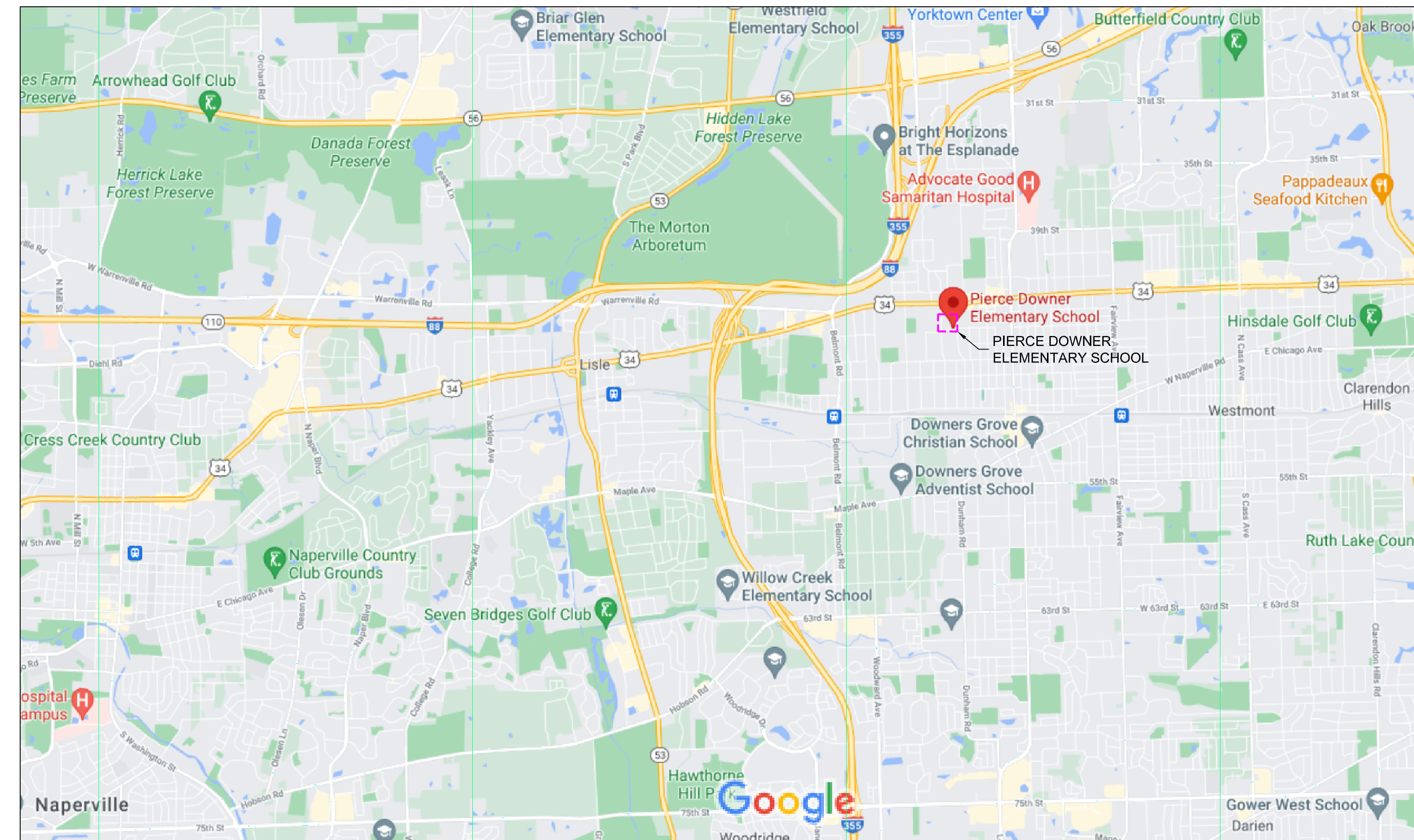

ADDRESS: 1436 GRANT STREET, DOWNERS GROVE, IL 60515  
TOWNSHIP 38N  
RANGE 11E  
SECTION 5

## INDEX OF DRAWINGS

### LANDSCAPE

L0.00	COVER SHEET
L0.01	GENERAL NOTES
L1.00-L1.01	OVERALL EXISTING CONDITIONS AND DEMOLITION PLAN
L2.00	SITE PLAN
L3.00	GRADING AND UTILITY PLAN
L3.01	UTILITY PROFILE PLAN
L4.00	LANDSCAPE PLAN
L5.00-L5.02	DETAILS

## UTILITY LOCATE

FOR UNDERGROUND UTILITY  
LOCATIONS, CALL J.U.L.I.E.  
TOLL FREE (800) 892-0123

JULIE SUBURBS & DIGG CHICAGO

- YELLOW ——— GAS
- RED ——— ELECTRICAL
- ORANGE ——— PHONE / TV COMMUNICATION
- BLUE ——— WATER
- GREEN ——— SEWERS
- WHITE ——— SAFE TO DIG

## BENCHMARKS

REFERENCE BENCHMARK (UTILIZED):  
DUPAGE COUNTY GEODETIC SURVEY MONUMENT #0005  
PID: DK3311

BRASS DISK IN CONCRETE AT NORTHEAST CORNER OF THE  
INTERSECTION OF CURTISS STREET AND MACKIE PLACE  
ELEVATION = 714.33  
DATUM: NAVD 88

SITE BENCHMARKS:  
SITE BENCHMARK #1

NORTHEAST BONNET BOLT ON FIRE HYDRANT APPROXIMATELY 30  
FEET SOUTH OF NORTHEAST CORNER OF SITE, WEST FO R.O.W.  
OF OAKWOOD AVENUE  
ELEVATION = 746.57  
DATUM: NAVD

88  
SITE BENCHMARK #2

NORTHEAST BONNET BOLT AT SOUTHWEST CORNER OF  
INTERSECTION OF GRANT STREET AND SEELEY AVENUE  
ELEVATION = 758.13  
DATUM: NAVD 88

SITE BENCHMARK #3

CUT SQUARE ON SOUTH SIDE OF CONCRETE LIGHT POLE BASE  
APPROXIMATELY 60 FEET SOUTHEAST OF SOUTHWEST CORNER  
OF SCHOOL BUILDING ON SITE  
ELEVATION = 743.95  
DATUM: NAVD 88

SITE BENCHMARK #4

NORTHWEST BONNET BOLT ON FIRE HYDRANT AT THE  
SOUTHWEST CORNER OF THE INTERSECTION OF GRANT STREET  
AND OAKWOOD AVENUE  
ELEVATION = 736.58  
DATUM: NAVD 88

REFERENCE BENCHMARK (NOTED):  
DUPAGE COUNTY GEODETIC SURVEY MONUMENT  
#0006  
PID: DK3312

3.5" BRASS DISK SET IN CONCRETE ±0.2'  
ABOVE GRADE AT NORTHEAST CORNER OF  
WASHINGTON STREET AND WARREN AVENUE  
ELEVATION = 718.78  
DATUM: NAVD 88

## SITE CONTROL

CONTROL POINT #500  
CUT CROSS IN WALK AT NORTHEAST CORNER OF SITE  
ELEVATION= 744.57  
NORTHING= 187276.42  
EASTING= 1069828.85

CONTROL POINT #501  
CUT CROSS IN WALK NEAR SOUTHEAST CORNER OF SITE  
ELEVATION= 735.54  
NORTHING= 1871836.44  
EASTING=106984.04

CONTROL POINT #502  
CUT CROSS IN WALK ON SOUTH SIDE OF SCHOOL OPPOSITE OF #1423  
GRANT STREET ON NORTH SIDE OF GRANT STREET  
ELEVATION=743.85  
NORTHING= 1871775.32  
EASTING= 1069569.67

CONTROL POINT #503  
CUT CROSS IN WALK APPROXIMATELY 27 FEET NORTH OF THE NORTHEAST  
CORNER OF THE INTERSECTION OF GRANT STREET AND SEELEY AVENUE  
ELEVATION= 756.87  
NORTHING= 1871735.91  
EASTING= 1069246.71

## ENGINEER'S CERTIFICATION

I HEREBY CERTIFY THAT THESE PLANS WERE PREPARED  
UNDER MY DIRECT SUPERVISION.

DATED AT DARIEN, ILLINOIS,

THIS \_\_\_\_\_ DAY OF \_\_\_\_\_, 20\_\_\_\_.

SIGNED: \_\_\_\_\_  
ENGINEER

EXPIRATION DATE: NOVEMBER 30, 20\_\_\_\_.

ISSUE FOR BID	1/19/2023
PERMIT SET	12/02/22
REV	DESCRIPTION DATE

## PIERCE DOWNER PLAYGROUND IMPROVEMENTS - PHASE 2

1436 GRANT STREET  
DOWNERS GROVE, IL 60515

## COVER SHEET

Project Number:  
210139  
Drawn By:  
LR  
Sheet:

# L0.00

**GENERAL**

- EXISTING SITE TOPOGRAPHY, UTILITIES, AND HORIZONTAL CONTROL SHOWN ON THE DRAWINGS WERE FIELD MEASURED BY COMPASS SURVEYING LTD., DATED 11/9/2013. UNDERGROUND UTILITY LOCATIONS ARE BASED ON BEST AVAILABLE INFORMATION. TRADE CONTRACTOR IS RESPONSIBLE FOR VERIFYING ALL UTILITY LOCATIONS, INVERTS, RINGS, PIPE SIZE, MATERIAL TYPE, ETC. PRIOR TO CONSTRUCTION. ANY DISCREPANCIES SHALL BE BROUGHT TO THE ATTENTION OF THE ENGINEER IMMEDIATELY.
- ELEVATIONS ARE BASED ON ILLINOIS STATE PLANE COORDINATE SYSTEM NAVD 88 DATUM.
- THE TRADE CONTRACTOR SHALL SUBSCRIBE TO ALL GOVERNING REGULATIONS AND SHALL ABIDE BY THE REQUIREMENTS OF ALL APPLICABLE PERMITS.
- ALL APPLICABLE PROVISIONS OF THE CURRENT OCCUPATIONAL HEALTH AND SAFETY ACT ARE HEREIN INCORPORATED BY REFERENCE.
- NO BURNING OR INCINERATION OF RUBBISH IS PERMITTED ON THE SITE.
- STREET AND DRIVEWAY PAVEMENT SHALL BE PROTECTED FROM DAMAGE, ANY DAMAGE SHALL BE REPAIRED PER THE VILLAGE OF DOWNERS GROVE REQUIREMENTS. MATERIALS AND WORKMANSHIP OF REPAIRS SHALL CONFORM TO THE "DOT STANDARD SPECIFICATIONS FOR ROAD AND BRIDGE CONSTRUCTION IN ILLINOIS (LATEST EDITION), THE SUPPLEMENTAL SPECIFICATIONS AND RECURRING SPECIAL PROVISIONS (LATEST EDITION)", HEREIN AFTER REFERRED TO AS "STANDARD SPECIFICATIONS" AND THE VILLAGE OF DOWNERS GROVE REQUIREMENTS.
- THE "DEVELOPMENT REGULATIONS", LATEST EDITION, AS ADOPTED BY THE VILLAGE OF DOWNERS GROVE, ILLINOIS, HEREIN AFTER REFERRED TO AS THE "DEVELOPMENT REGULATIONS" INCLUDING ALL VILLAGE STANDARD DETAILS AND SPECIFICATIONS; THE "STANDARD SPECIFICATIONS FOR ROAD AND BRIDGE CONSTRUCTION (LATEST EDITION) AND THE SUPPLEMENTAL SPECIFICATIONS AND RECURRING SPECIAL PROVISIONS (LATEST EDITION)" PREPARED BY ILLINOIS DEPARTMENT OF TRANSPORTATION (IDOT), HEREIN AFTER REFERRED TO AS THE "STANDARD SPECIFICATIONS"; AND ILLINOIS ENVIRONMENTAL PROTECTION AGENCY ILLINOIS URBAN MANUAL, LATEST EDITION, AND "STANDARD SPECIFICATIONS FOR WATER AND SEWER MAIN CONSTRUCTION IN ILLINOIS", HEREIN AFTER REFERRED TO AS "ISPE STANDARDS" SHALL GOVERN THE CONSTRUCTION OF THESE IMPROVEMENTS EXCEPT AS MODIFIED BY THE CONTRACT DOCUMENTS.
- ALL CONNECTIONS TO EXISTING UTILITIES SHALL BE CONSTRUCTED IN ACCORDANCE WITH THE REGULATIONS OF THE VILLAGE OF DOWNERS GROVE, ILLINOIS AND THE STANDARD SPECIFICATIONS FOR WATER AND SEWER MAIN CONSTRUCTION IN ILLINOIS, HEREIN AFTER REFERRED TO AS ISPE STANDARDS.
- ALL FACILITIES OR LANDSCAPING DAMAGED DURING CONSTRUCTION SHALL BE RESTORED TO ORIGINAL CONDITION BY THE RESPONSIBLE TRADE CONTRACTOR.
- PROPOSED ELEVATIONS INDICATE FINISHED GRADES. FOR SUBGRADE ELEVATIONS, ALLOW FOR THICKNESS OF PROPOSED PAVING OR TOPSOIL THICKNESS.
- THE TRADE CONTRACTOR SHALL NOTIFY THE VILLAGE OF DOWNERS GROVE, ILLINOIS 48 HOURS BEFORE THE COMMENCEMENT OF CONSTRUCTION.
- SHOULD THE TRADE CONTRACTOR ENCOUNTER FIELD DRAINAGE TILE NOT SHOWN ON THE DRAWINGS, THE CONTRACTOR SHALL IMMEDIATELY CONTACT ENGINEER AND THE VILLAGE OF DOWNERS GROVE FOR INSTRUCTIONS. SHOULD THE ENGINEER OR VILLAGE OF DOWNERS GROVE INSTRUCT THAT DAMAGED FIELD TILES BE RESTORED TO THEIR ORIGINAL CONDITION, THAT REPAIR SHALL BE CONSIDERED INCIDENTAL TO THE CONTRACT. THE LOCATION OF FOUND DRAINAGE TILE SHALL BE INDICATED ON THE RECORD DRAWING.
- ALL TRENCHES SHOULD FOLLOW THE VILLAGE OF DOWNERS GROVE STANDARD DETAILS INCLUDED IN THE CIVIL DETAILS. TRENCHES ARE TO BE BACKFILLED WITH TRENCH BACKFILL AND COMPACTED TO 95% MODIFIED PROCTOR DENSITY, AS REQUIRED BY THE VILLAGE OF DOWNERS GROVE AND THE ISPE STANDARDS.
- TRADE CONTRACTOR IS RESPONSIBLE FOR CALLING J.U.L.I.E. AT 1-800-892-0123 OR 811 AND NOTIFYING THE CONSTRUCTION MANAGER AT LEAST 48 HOURS PRIOR TO BEGINNING ANY EXCAVATION; CONTRACTOR IS RESPONSIBLE FOR MAINTAINING UTILITY MARKINGS THROUGHOUT CONSTRUCTION.
- ALL DIMENSIONS, CURB RADII AND ELEVATIONS REFER TO THE BACK OF CURB WHERE CURB IS SHOWN. COORDINATES ARE TO BACK OF CURB, CENTER OF STRUCTURES OR AS SHOWN.
- WHERE PAVEMENT, CURB OR SIDEWALK REMOVAL IS REQUIRED, THE TRADE CONTRACTOR SHALL SAW CUT THE BOUNDARIES OF THE AREA TO BE REMOVED PRIOR TO DEMOLITION.
- TRADE CONTRACTOR IS RESPONSIBLE FOR LAYOUT, LINE AND GRADE FOR ITEMS INCLUDED IN THE CONTRACT SCOPE OF WORK, CONTRACTOR TO USE CAD FILES AS PROVIDED BY THE ENGINEER FOR GEOMETRIC LAYOUT.
- TRADE CONTRACTOR IS RESPONSIBLE FOR KEEPING THE PUBLIC STREET CLEAN OF DEBRIS.
- "BAND SEAL" JOINTS WITH STAINLESS STEEL STRAPS AND BOLTS SHALL BE USED WHEN CONNECTING DISSIMILAR MATERIALS.
- ALL EXISTING UTILITY STRUCTURES SHALL BE ADJUSTED AS NECESSARY TO MATCH FINISH GRADE. ALL EXISTING UTILITY STRUCTURES REQUIRING ADJUSTMENT OR RECONSTRUCTION SHALL BE COMPLETED BY THE CONTRACTOR TO THE SATISFACTION OF THE UTILITY OWNER. ADJUSTMENTS AND/OR RECONSTRUCTIONS NOT CALLED FOR ON THE PLANS SHALL BE CONSIDERED INCIDENTAL TO THE CONTRACT. NO MORE THAN A TOTAL OF 12 INCHES OF ADJUSTING RINGS AND/OR 2 ADJUSTING RINGS SHALL BE ALLOWED.
- IF EXISTING UTILITY LINES OF ANY NATURE ARE ENCOUNTERED WHICH CONFLICT IN LOCATION AND/OR ELEVATION WITH NEW CONSTRUCTION, THE CONTRACTOR SHALL NOTIFY THE ENGINEER AND CONSTRUCTION MANAGER SO THAT THE CONFLICT MAY BE RESOLVED.
- THE CONTRACTOR IS RESPONSIBLE FOR ALL AS-BUILT SURVEYS. ALL AS-BUILT SURVEYS SHALL BE COMPLETED BY A PROFESSIONAL LAND SURVEYOR AND BE SIGNED AND SEALED. THE CONTRACTOR SHALL SUBMIT TWO SETS OF THE "AS-BUILT" FINAL ENGINEERING DRAWINGS (I.E. RECORD DRAWINGS) AND STORMWATER MANAGEMENT CALCULATIONS UPON COMPLETION OF THE PROJECT AND INCLUDING CAD FILES. THE RECORD DRAWINGS SHOULD AT LEAST INCLUDE THE FOLLOWING INFORMATION: AS-BUILT DETENTION CONTOURS, ELEVATIONS (INCLUDING DETENTION BASIN TOP OF BERM AND OVERFLOW WEIR GRADES) AND VOLUME (VERIFIED, SIGNED, & SEALED BY A PROFESSIONAL ENGINEER (PE) OR PROFESSIONAL LAND SURVEYOR (PLS)); ELEVATION, AND LOCATION (TIES TO TWO POINTS) OF ALL NEW STRUCTURES INCLUDING FIRE HYDRANTS, VALVE BOXES AND VAULTS, LINED TOP SLEEVES, WATER SERVICE CORPORATION STOPS, WATER MAIN FITTINGS/BENDS, MANHOLES, SANITARY SERVICE WYES (MEASURED FROM DOWNSTREAM MANHOLE), ALL STORM SANITARY SEWER STRUCTURES (INCLUDING INVERTS AND PIPE SIZES), ALL PIPES (LOCATIONS, SLOPES, LENGTHS, ETC.), OUTLET CONTROL STRUCTURES (INCLUDING RESTRICTOR SIZES AND ELEVATIONS PLUS TOP OF WALL) AND ABANDONED WATER OR SANITARY SERVICE LINES. DETAILED TOPOGRAPHIC SURVEY OF ALL HIGH POINTS, LOW POINTS, CHANGES OF SLOPE INCLUDING GUTTER GRADES, TOP OF CURB GRADES, PAVEMENT GRADES, SIDEWALK GRADES, RAMP GRADES, ETC. TO VERIFY POSITIVE DRAINAGE. ALL ELEVATIONS SHOULD BE REFERENCED TO THE SAME BENCHMARK DATUM AS THE ORIGINAL DESIGN PLANS. HORIZONTAL TIES SHALL BE REFERENCED TO LOT LINES, BACK OF CURB, OR PROPERTY CORNERS, WITHIN DETENTION/BMP AREAS. FOR VERIFICATION OF DETENTION VOLUME AND SUBBASE GRADES, PRIOR TO BACK FILLING WITH CA-2, THE CONTRACTOR SHALL PROVIDE ENGINEER WITH A CERTIFIED TOPO SURVEY OF AS-BUILT SUBBASE GRADES FOR ENGINEER APPROVAL, AND ALSO A COPY OF RECEIPT OF THE CA-7 AGGREGATE.
- EMERGENCY VEHICLE ACCESS IS TO BE MAINTAINED THROUGHOUT DURATION OF PROJECT. VEHICLE ACCESS IS TO BE CLEARLY MARKED. ANY ALTERATION OF EMERGENCY VEHICLE ROUTE OR ACCESS IS TO BE APPROVED BY THE VILLAGE OF DOWNERS GROVE, ILLINOIS.  
  
 VILLAGE CONTACT INFORMATION:  
 VILLAGE OF DOWNERS GROVE PUBLIC WORKS  
 5101 WALNUT AVENUE  
 DOWNERS GROVE, IL  
 630-434-5461  
 CONTACT: ANDY SIKICH, DIRECTOR OF PUBLIC WORKS
- TWO HARD COPIES OF AN AS-BUILT FINAL GRADING SURVEY MUST BE SUBMITTED PRIOR TO SCHEDULING THE FINAL STORMWATER/RIGHT-OF-WAY INSPECTION FOR THE PROJECT. AS APPLICABLE, IT SHALL INCLUDE, BUT IS NOT LIMITED TO THE ITEMS LISTED IN SECTION 26.700.C OF THE DOWNERS GROVE MUNICIPAL CODE. BEFORE THE PERMIT CAN BE CLOSED, AN ELECTRONIC COPY OF THE APPROVED AS-BUILT GRADING SURVEY IS REQUIRED.
- A FINAL INSPECTION IS REQUIRED AFTER THE WORK IS COMPLETE AND THE SITE IS STABILIZED (GRASS GROWING WITH 70% COVERAGE OR SOD/PLANTS/MULCH PLACED). CALL COMMUNITY DEVELOPMENT AT 630-434-5529 TO SCHEDULE AT LEAST 48 HOURS IN ADVANCE. AS-BUILT DRAWINGS WILL BE REQUIRED AT THAT TIME.

**TRAFFIC CONTROL**

- THE TRADE CONTRACTOR SHALL PROVIDE TRAFFIC CONTROL (IDOT STANDARD 701006) AT ALL TIMES WHEN ANY VEHICLES, EQUIPMENT, WORKER, OR ACTIVITY ENCR OACH ADJACENT ROADWAYS FROM 15 FEET TO THE EDGE OF PAVEMENT, THE TRADE CONTRACTOR SHALL PROVIDE TRAFFIC CONTROL (IDOT STANDARD 701501) WHEN ACTIVITY ENCR OACHES THE EDGE OF PAVEMENT FOR THESE ROADS.
- IF THE OPERATION IS 15 FEET OR MORE, OFF THE EDGE OF PAVEMENT, NO SIGNING WILL BE REQUIRED UNLESS TWO OR MORE VEHICLES CROSS THE 15 FOOT CLEAR ZONE IN ONE HOUR
- WHEN WORKING WITHIN 2 FEET OF THE PAVEMENT EDGE, CONES, DRUMS, OR BARRICADES SHALL BE PLACED ACCORDING TO THE STANDARD 701101 REQUIREMENTS.
- CONTRACTOR MUST FOLLOW ALL VILLAGE OF DOWNERS GROVE AND DUPAGE COUNTY DEPARTMENT OF TRANSPORTATION REQUIREMENTS FOR TRAFFIC CONTROL.

**EARTHWORK**

- ALL AREAS SHALL BE CLEARED AND TILLED IN PREPARATION TO RECEIVE SEED. REFER TO SPECIFICATIONS FOR REQUIREMENTS.
- THE TRADE CONTRACTOR SHALL APPLY FERTILIZER AND SEED TO ALL DISTURBED AREAS. AS NOTED ON THE CONSTRUCTION DRAWINGS, TRADE CONTRACTOR SHALL APPLY FERTILIZER AND SEED USING THE HYDROSEED METHOD. FERTILIZER AND SEED QUANTITIES AND SEEDING PROCEDURES SHALL CONFORM TO THE SPECIFICATIONS.
- THE TRADE CONTRACTOR WILL INSPECT THE SEEDED AREAS AFTER SEEDING. TO RECEIVE FINAL ACCEPTANCE, SEEDED AREAS MUST SUPPORT DENSE, THRIVING GRASSES SUFFICIENT TO PROTECT THE SOIL FROM EROSION IN A MODERATE RAINFALL AREAS THAT, IN THE OPINION OF THE OWNER & ENGINEER, DO NOT MEET THIS REQUIREMENT, MUST BE IMMEDIATELY RESEED. REFER TO SPECIFICATIONS FOR ALL REQUIREMENTS.
- TOPSOIL FOR RESTORATION AREAS SHALL COMPLY WITH THE STANDARD SPECIFICATIONS. TOPSOIL MAY BE SALVAGED FROM THE SITE AND STOCKPILED FOR REUSE WHEN ALL WORK IS COMPLETED, ADDITIONAL TOPSOIL REQUIRED TO COMPLETE THE JOB SHALL BE OBTAINED FROM OFF-SITE SOURCES AT THE TRADE CONTRACTOR'S EXPENSE. SALVAGED TOPSOIL SHALL BE SUBJECT TO THE ENGINEER'S APPROVAL AND WILL BE REJECTED IF NOT CLEAN, UNCONTAMINATED MATERIAL.
- THE CROWNS AND ROOT OF TREES WHICH ARE TO BE PRESERVED IN THE PROJECT AREA, BUT WHICH COULD BE NEGATIVELY AFFECTED DURING THE CONSTRUCTION PROCESS, SHALL BE PRUNED BY A QUALIFIED ARBORIST ACCORDING TO THE TREE PRUNING STANDARDS SET BY ANSI Z100 CODE.
- POROUS GRANULAR EMBANKMENT, SUBGRADE  
  
 THIS WORK CONSISTS OF FURNISHING, PLACING, AND COMPACTING POROUS GRANULAR MATERIAL AS DIRECTED BY THE ENGINEER. POROUS GRANULAR EMBANKMENT SHALL CONSIST OF CA-1 AGGREGATE CAPPED WITH A 3 INCHES NOMINAL THICKNESS TOP LIFT OF CA-6 CAPPING AGGREGATE. THE MATERIAL SHALL BE USED AS A BRIDGING LAYER OVER SOFT, PUMPY, AND LOOSE SOIL AND SHALL CONFORM.

THE POROUS GRANULAR MATERIAL SHALL BE PLACED IN ONE LIFT WHEN THE TOTAL THICKNESS TO BE PLACED IS 2 FEET OR LESS OR AS DIRECTED BY THE ENGINEER. EACH LIFT OF THE POROUS GRANULAR MATERIAL SHALL BE ROLLED WITH A VIBRATORY ROLLER MEETING THE REQUIREMENTS OF THE STANDARD SPECIFICATIONS TO OBTAIN THE DESIRED KEYING OR INTERLOCK AND COMPACTION. THE ENGINEER SHALL VERIFY THAT ADEQUATE KEYING HAS BEEN OBTAINED.

CONSTRUCTION EQUIPMENT NOT NECESSARY FOR THE COMPLETION OF THE REPLACEMENT MATERIAL WILL NOT BE ALLOWED ON THE UNDERCUT AREAS UNTIL COMPLETION OF THE RECOMMENDED THICKNESS OF THE POROUS GRANULAR EMBANKMENT SUBGRADE.

FULL DEPTH SUBGRADE UNDERCUT SHOULD OCCUR AT LIMITS DETERMINED BY THE ENGINEER. A TRANSITION SLOPE TO THE FULL DEPTH OF UNDERCUT SHALL BE MADE OUTSIDE OF THE UNDERCUT LIMITS AT A TAPER OF 1 FOOT LONGITUDINAL PER 1 INCH DEPTH BELOW THE PROPOSED SUBGRADE OR BOTTOM OF THE PROPOSED AGGREGATE SUBGRADE WHEN INCLUDED IN THE CONTRACT.

THIS WORK WILL BE MEASURED FOR PAYMENT IN ACCORDANCE WITH THE STANDARD SPECIFICATIONS, WHEN SPECIFIED ON THE CONTRACT. THE THEORETICAL ELEVATION OF THE BOTTOM OF THE AGGREGATE SUBGRADE SHALL BE USED TO DETERMINE THE UPPER LIMIT OF POROUS GRANULAR EMBANKMENT, SUBGRADE. THE VOLUME WILL BE COMPUTED BY THE METHOD OF AVERAGE END AREAS.

THIS WORK SHALL BE PAID FOR AT THE CONTRACT UNIT PRICE PER CUBIC YARD FOR POROUS GRANULAR EMBANKMENT, SUBGRADE WHICH PRICE SHALL INCLUDE THE CAPPING AGGREGATE, WHEN REQUIRED.

THE POROUS GRANULAR EMBANKMENT, SUBGRADE SHALL BE USED AS FIELD CONDITIONS WARRANT AT THE TIME OF CONSTRUCTION.

- SPECIAL EXCAVATION  
  
 WORK UNDER THIS ITEM SHALL BE PERFORMED IN ACCORDANCE WITH THE STANDARD SPECIFICATIONS EXCEPT AS HEREIN MODIFIED.  
  
 SPECIAL EXCAVATION SHALL INCLUDE THE SATISFACTORY REMOVAL AND OFF-SITE DISPOSAL OF ALL UNSUITABLE MATERIAL BELOW THE SUBGRADE ELEVATION.  
  
 AFTER EXCAVATING TO THE REQUIRED SUBGRADE LEVEL, THE ENGINEER & GEOTECH ENGINEER SHALL INSPECT THE SUBGRADE. PRIOR TO PLACING ANY PAVEMENT SECTION MATERIAL, THE EXCAVATION LEVEL OR SUBGRADE LEVEL SHALL BE COMPACTED AND, WHERE POSSIBLE, PROOF ROLLED WITH A 40,000 LB TANDEM AXLE TRUCK BY MAKING AT LEAST 4 PASSES. THE COMPACTING AND PROOF ROLLING WILL DETECT SOFT OR UNSTABLE POCKETS OF MATERIAL WHICH SHALL BE REMOVED AND REPLACED AS HEREIN SPECIFIED. THE COMPACTING AND PROOF ROLLING SHALL BE INCIDENTAL TO THE WORK AND NO ADDITIONAL COMPENSATION WILL BE PAID.  
  
 IF THE EXISTING SUBGRADE SOIL IS NOT SUITABLE FOR PROVIDING AN IBR SOIL SUPPORT VALUE OF 2, THE TRADE CONTRACTOR SHALL REMOVE THE UNSUITABLE SUBGRADE SOIL BELOW THE PROPOSED SUBGRADE LEVEL TO A DEPTH AS DIRECTED BY THE ENGINEER. COMPACT AND PROOF ROLL THE EXCAVATED AREA. IF UPON PROOF ROLLING THE SUBGRADE IS STILL UNSUITABLE, ADDITIONAL EXCAVATION MAY BE REQUIRED. NO ADDITIONAL COMPENSATION WILL BE MADE REGARDLESS OF THE NUMBER OF TIMES THE AREA IS COMPACTED AND PROOF ROLLED.  
  
 CA-1 SHALL BE USED TO BRING THE SUBGRADE TO THE PROPOSED ELEVATION AS INDICATED UNDER THE ITEM POROUS GRANULAR EMBANKMENT, SUBGRADE, POROUS GRANULAR EMBANKMENT, SUBGRADE IS NOT CONSIDERED PART OF THIS ITEM.  
  
 THOSE AREAS OF SUBGRADE WHICH ARE NOT OVER EXCAVATED SHALL ALSO BE COMPACTED TO 95% OF MAXIMUM DENSITY AS DETERMINED BY AASHTO T-99.  
  
 SPECIAL EXCAVATION AS SHOWN ON THE PLANS AND AS DIRECTED BY THE ENGINEER WILL BE MEASURED FOR PAYMENT IN PLACE AND THE VOLUME IN CUBIC YARDS COMPUTED BY THE METHOD OF AVERAGE END AREAS. EXCAVATION IN EXCESS OF THAT AUTHORIZED SHALL NOT BE MEASURED FOR PAYMENT.  
  
 THIS WORK SHALL BE PAID FOR AT THE CONTRACT UNIT CUBIC YARD FOR SPECIAL EXCAVATION, WHICH PRICE SHALL INCLUDE ALL COSTS ASSOCIATED WITH UNSUITABLE MATERIAL REMOVAL AND LEGAL DISPOSAL, GRADING COMPACTING AND PROOF ROLLING OF SUBGRADE.

- THE OWNER IS REQUIRED TO HAVE A GEOTECHNICAL ENGINEER ON-SITE TO MONITOR EARTHWORK, AND THE GRADING ACTIVITY, IN ORDER TO IDENTIFY UNSUITABLE SOILS FOR REMOVAL FROM THE SITE. CONTRACTOR TO ENSURE REQUIREMENTS ARE MET.

**SEDIMENT AND EROSION CONTROL**

- AN INITIAL SEDIMENTATION AND EROSION CONTROL INSPECTION IS REQUIRED PRIOR TO STARTING CONSTRUCTION. THE APPLICANT IS DIRECTED TO CONTACT THE COMMUNITY DEVELOPMENT DEPARTMENT AT 630-434-5529 TO SCHEDULE THIS INSPECTION; THIS NOTIFICATION SHALL BE AT LEAST 24 HOURS IN ADVANCE OF CONSTRUCTION.
- THE SEDIMENT AND EROSION CONTROL DEVICES SHALL BE FUNCTIONAL BEFORE ANY LAND IS DISTURBED ON THE SITE.
- STOCKPILES OF SOIL SHALL NOT BE LOCATED WITHIN ANY DRAINAGEWAYS, FLOODPLAINS, WETLANDS, BUFFERS OR LPDAS.
- SEDIMENT AND EROSION CONTROL SHALL BE PROVIDED FOR ANY SOIL STOCKPILE IF IT IS TO REMAIN IN PLACE FOR MORE THAN THREE DAYS INCLUDING A DOUBLE ROW OF SILT FENCE OR COIR ROLL.
- PROPERTIES DOWNSTREAM FROM THE SITE SHALL BE PROTECTED FROM EROSION IF THE VOLUME, VELOCITY, SEDIMENT LOAD, OR PEAK FLOW RATES OF STORMWATER RUNOFF ARE TEMPORARILY INCREASED DURING CONSTRUCTION.
- STORM SEWER INLETS SHALL BE PROTECTED WITH SEDIMENT TRAPPING OR FILTER CONTROL DEVICES DURING CONSTRUCTION.
- THE SURFACE OF STRIPPED AREAS SHALL BE PERMANENTLY OR TEMPORARILY PROTECTED FROM SOIL EROSION WITHIN SEVEN (7) DAYS AFTER FINAL GRADE IS REACHED. STRIPPED AREAS THAT WILL REMAIN UNDISTURBED FOR MORE THAN SEVEN (7) DAYS AFTER INITIAL DISTURBANCE SHALL BE PROTECTED FROM EROSION.
- WATER PUMPED OR OTHERWISE DISCHARGED FROM THE SITE DURING CONSTRUCTION DEWATERING SHALL BE FILTERED.
- A STABILIZED CONSTRUCTION ENTRANCE SHALL BE PROVIDED TO PREVENT THE DEPOSITION OF SOIL ONTO PUBLIC OR PRIVATE ROADWAYS. ANY SOIL REACHING A PUBLIC OR PRIVATE ROADWAY SHALL BE REMOVED BEFORE THE END OF EACH WORKDAY.
- ALL TEMPORARY EROSION CONTROL MEASURES NECESSARY TO MEET THE REQUIREMENTS OF THE VILLAGE OF DOWNERS GROVE STORMWATER AND FLOOD PLAIN ORDINANCE SHALL BE KEPT OPERATIONAL AND MAINTAINED CONTINUOUSLY THROUGHOUT THE PERIOD OF LAND DISTURBANCE UNTIL PERMANENT SEDIMENT AND EROSION AND CONTROL MEASURES ARE OPERATIONAL.
- ALL TEMPORARY EROSION AND SEDIMENT CONTROL MEASURES SHALL BE REMOVED WITHIN THIRTY (30) DAYS AFTER FINAL STABILIZATION IS ACHIEVED. TRAPPED SEDIMENT AND OTHER DISTURBED SOILS RESULTING FROM TEMPORARY MEASURES SHALL BE PROPERLY DISPOSED OF PRIOR TO PERMANENT STABILIZATION.
- TRADE CONTRACTOR SHALL ABIDE BY EROSION CONTROL MEASURES OUTLINED IN THE "ILLINOIS URBAN MANUAL, LATEST EDITION" BY THE ILLINOIS ENVIRONMENTAL PROTECTION AGENCY (IEPA).
- SILT FENCING AND OTHER EROSION CONTROL DEVICES SHALL BE INSTALLED BY THE TRADE CONTRACTOR PRIOR TO THE BEGINNING OF CONSTRUCTION ACTIVITIES TO THE LIMITS DELINEATED ON THE PLANS. NO DISTURBANCE OF LAND IS ALLOWED OUTSIDE THE SILT FENCE AND PROJECT LIMITS AS INDICATED ON THE PLANS.
- ALL TEMPORARY AND PERMANENT EROSION AND SEDIMENT CONTROL PRACTICES MUST BE INSPECTED WEEKLY AND MAINTAINED. INSPECTIONS SHALL ALSO BE MADE IN THE EVENT OF 1/2 INCH OR GREATER OR EQUIVALENT SNOW FALL EVENT. IF NECESSARY, REPAIR OR REPLACEMENT MUST BE PERFORMED IMMEDIATELY TO ASSURE EFFECTIVE PERFORMANCE OF THEIR INTENDED FUNCTIONS.
- IF DEWATERING DEVICES ARE USED, DISCHARGE LOCATIONS SHALL BE PROTECTED FROM EROSION. ALL PUMPED DISCHARGES SHALL BE ROUTED THROUGH APPROPRIATELY DESIGNED SEDIMENT TRAPS, BASINS, SEDIMENT FILTER BAGS OR EQUIVALENT MEASURES.
- STABILIZATION OF DISTURBED AREAS MUST BE INITIATED WITHIN 1 WORKING DAY OR PERMANENT OR TEMPORARY CESSATION OF EARTH DISTURBING ACTIVITIES AND SHALL BE COMPLETED AS SOON AS POSSIBLE BUT NOT LATER THAN 7 DAYS FROM THE INITIATION OF STABILIZATION WORK IN AN AREA.
- MAJOR AMENDMENTS OF THE SITE DEVELOPMENT OR EROSION AND SEDIMENTATION CONTROL PLANS SHALL BE SUBMITTED TO THE MUNICIPALITY TO BE APPROVED IN THE SAME MANNER AS THE ORIGINAL PLANS.
- THE TRADE CONTRACTOR SHALL STABILIZE THE SIDE SLOPES GREATER THAN 10:1 OR WHERE SHOWN ON THE PLANS BY INSTALLING NORTH AMERICAN GREEN SCI1508N EROSION CONTROL BLANKET, WITHIN 5 DAYS AFTER FINAL GRADE IS ACHIEVED AND FOLLOWING SEEDING WITH THE TEMPORARY SEED MATRIX. THE EROSION CONTROL BLANKET SHALL BE INSTALLED AS REQUIRED BY THE MANUFACTURER'S STANDARDS AND SPECIFICATIONS.
- TEMPORARY STOCKPILES SHALL HAVE A SILT FENCE ERRECTED AROUND THE PERIMETER OF THE PILE. IF A PILE IS TO REMAIN IN PLACE FOR MORE THAN 14 DAYS, IT SHALL BE TEMPORARY SEEDED.
- SOIL STOCKPILE LOCATIONS MAY BE LOCATED BY THE CONTRACTOR AS NECESSARY ONSITE AND DO NOT NEED TO MATCH EXACT LOCATION AS SHOWN ON THE EROSION AND SEDIMENT CONTROL PLAN. PROVIDE SILT FENCE AROUND ALL STOCKPILE LOCATIONS. NO STOCKPILES SHALL BE PLACED IN THE PROPOSED DETENTION POND OR BE PLACED IN FLOOD PROTECTION AREAS OR THEIR BUFFERS.
- IF AN EXISTING ON-SITE ASPHALT ACCESS IS NOT PRESENT THEN, THE TRADE CONTRACTOR SHALL PROVIDE A CONSTRUCTION ACCESS ROAD CONSTRUCTED OF DOT CA-1 FOR 100 FEET IN LENGTH. THE TRADE CONTRACTOR SHALL MAINTAIN THE ADJACENT ROADS FREE OF MUD AND SEDIMENT AT ALL TIMES. REFER TO THE ILLINOIS URBAN MANUAL STANDARD DRAWING IL-630.
- ALL ACCESS TO AND FROM THE CONSTRUCTION SITE IS TO BE RESTRICTED TO THE CONSTRUCTION ENTRANCE.
- TRADE CONTRACTOR IS RESPONSIBLE FOR KEEPING PUBLIC STREETS CLEAR OF DIRT, DUST, DEBRIS AND MUD ON A DAILY BASIS FOR THE ENTIRE CONSTRUCTION PERIOD BY A MEANS ACCEPTABLE TO LOCAL AUTHORITIES.
- ANY SEDIMENT REACHING A PUBLIC OR PRIVATE ROAD SHALL BE REMOVED BY SHOVELING OR STREET CLEANING (NOT FLUSHING) BEFORE THE END OF EACH WORKDAY AND TRANSPORTED TO A CONTROLLED SEDIMENT DISPOSAL.
- A SWPPP IS NOT ANTICIPATED FOR THIS DEVELOPMENT SINCE THE DISTURBED AREA IS LESS THAN 1.0 ACRES

**ABBREVIATIONS**

A	ARC LENGTH	MH	MANHOLE
B/C	BACK OF CURB	N.D.I.	NO DISTURB LINE
B-B	BACK-TO-BACK OF CURB	N.I.C.	NOT IN CONTRACT
BIT	BITUMINOUS PAVEMENT	N.W.E.	NORMAL WATER ELEVATION
BUILD	BUILDING LINE	P.I.	POINT OF INTERSECTION
BENCH	BENCH MARK	P.R.C.	POINT OF REVERSE CURVATURE
BRW	BOTTOM OF RETAINING WALL	PVC	POLYVINYL CHLORIDE
B/W	BACK OF SIDEWALK	P.T.	POINT OF TANGENCY
CHDPE	CORRUGATED HIGH DENSITY POLYETHYLENE PIPE	P.L.	PROPERTY LINE
CO	CLEAN OUT	P.C.	POINT OF CURVATURE
C & G	CURB AND GUTTER	P.V.	POINT OF VERTICAL INTERSECTION
C.B.	CATCH BASIN	P.G.	PROFILE GRADE
CP	CONTROL POINT	R	RADIUS
DWG.	DRAWING	RCP	REINFORCED CONCRETE PIPE
D.I.P.	DUCTILE IRON PIPE	REC	RECORD DIMENSION
DIA.	DIAMETER	R.O.W.	RIGHT-OF-WAY
D	DISTANCE	RT	RIGHT
DC	DEPRESSED CURB	SHT	SHEET
D.E.	DRAINAGE EASEMENT	S	SLOPE
D.V.	DETENTION VOLUME	STA	STATION
DS	DOWNSPOUT	STMH	STORM MANHOLE
ELEV./ EL	ELEVATION	SAN	SANITARY
E/P	EDGE OF PAVEMENT	S.M.H.	SANITARY MANHOLE
E.J.	EXPANSION JOINT	T.E.	TOP ELEVATION
EX	EXISTING	V.C.	VERTICAL CURVE
F.G.	FINISH GRADE	V.T.	VERTIFIED HUB TILE
F-F	FACE-TO-FACE OF CURB OR STALL	V.B.	VALVE BOX
F/L	FLOW LINE	V.V.	VALVE VAULT
F.H.	FIRE HYDRANT	V.C.P.	VITRIFIED CLAY PIPE
F.E.S.	FLARED END SECTION	VER.	VERTICAL
FIP	FOUND IRON PIPE	W	WATER
H/W	HEADWALL	WM	WATER MAIN
GAV	GAS VALVE		
GF	GRADE AT FOUNDATION		
G.L.	GUTTER LINE		
G	GAS		
GR	GRADE ELEVATION		
GV/VV	GATE VALVE IN VALVE VAULT		
H/W	GATE VALVE IN VALVE BOX		
HOR.	HORIZONTAL		
H.W.E.	HIGH WATER ELEVATION		
I.E. / INV.	INVERT ELEVATION		
INL	INLET		
IRR.	IRRIGATION		
L	LENGTH		
L.P.	LIGHT POLE		
LT.	LEFT		
(M)	MEASURED BEARING OR DISTANCE		
M/E	MATCH EXISTING		
M.O.	MID ORDINATE		

**LEGEND**

EXISTING			
	STORM SEWER		FIRE HYDRANT
	SANITARY SEWER		WATER VALVE VAULT
	WATER MAIN		WATER VALVE BOX
	TELEPHONE		WATER BUFFALO BOX
	ELECTRICAL		WATER METER
	GAS MAIN		ELECTRIC METER
	GUARD RAIL		GAS METER
	EXISTING FENCE		GAS VALVE
	STORM MANHOLE		CLEANOUT
	CATCH BASIN		VILLAGE ELEC. MH
	INLET		COMED ELEC. MH
	FLARED END SECTION		TELEPHONE MH
	SANITARY MANHOLE		SOIL BORING
	DECIDUOUS TREE		LIGHT POLE
	EVERGREEN TREE		POWER POLE
	SIGN		TELEPHONE POLE

PROPOSED			
	COMBINED SEWER		FIBER OPTIC CONDUIT
	STORM SEWER		ELECTRIC LIGHT
	SANITARY SEWER		CLEANOUT ACCESS
	WATER MAIN		FIRE HYDRANT
	TELEPHONE		WATER VALVE VAULT
	ELECTRICAL		WATER VALVE BOX
	GAS MAIN		ELECTRIC MANHOLE
	GUARD RAIL		TELEPHONE PEDESTAL
	STORM MANHOLE		GAS METER
	CATCH BASIN		DOWNSPOUT
	SANITARY MANHOLE		
	DECIDUOUS TREE		
	SIGN		
	TELEVISION		
	ELECTRIC GENERATOR		
	ELECTRIC TRANSFORMER		
	ELECTRIC METER BOX		
	SILT FENCE		
	FENCE/GATE		



DOWNERS GROVE  
SCHOOL DISTRICT 58

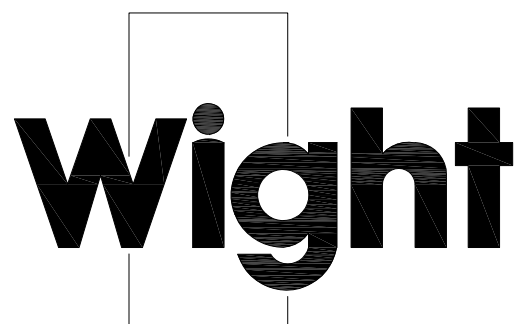

Wight & Company  
wightco.com

2500 North Frontage Road  
Darien, IL 60561

P 630.969.7000  
F 630.969.7979

ISSUE FOR BID	1/19/2023
PERMIT SET	12/02/22

REV	DESCRIPTION	DATE
-----	-------------	------

**PIERCE DOWNER  
PLAYGROUND  
IMPROVEMENTS -  
PHASE 2**  
1436 GRANT STREET  
DOWNERS GROVE, IL 60515

**GENERAL NOTES**

Project Number:  
210139  
Drawn By:  
LR  
Sheet:

**L0.01**

S:\Darien\Downers Grove SD58\210139\_Pierce Downer Playground\01\11 Drawings\02 CD\PHASE II\210139-L1.00 EXISTING CONDITIONS PH2.dwg kbuck Jan 19, 2023 9:49:46 am  
 Wight © Copyright All rights reserved. No part of these documents may be reproduced, stored, or transmitted in any form or by any means, electronic, mechanical, photocopying, recording or otherwise, without the prior written consent of Wight.



**LEGEND**

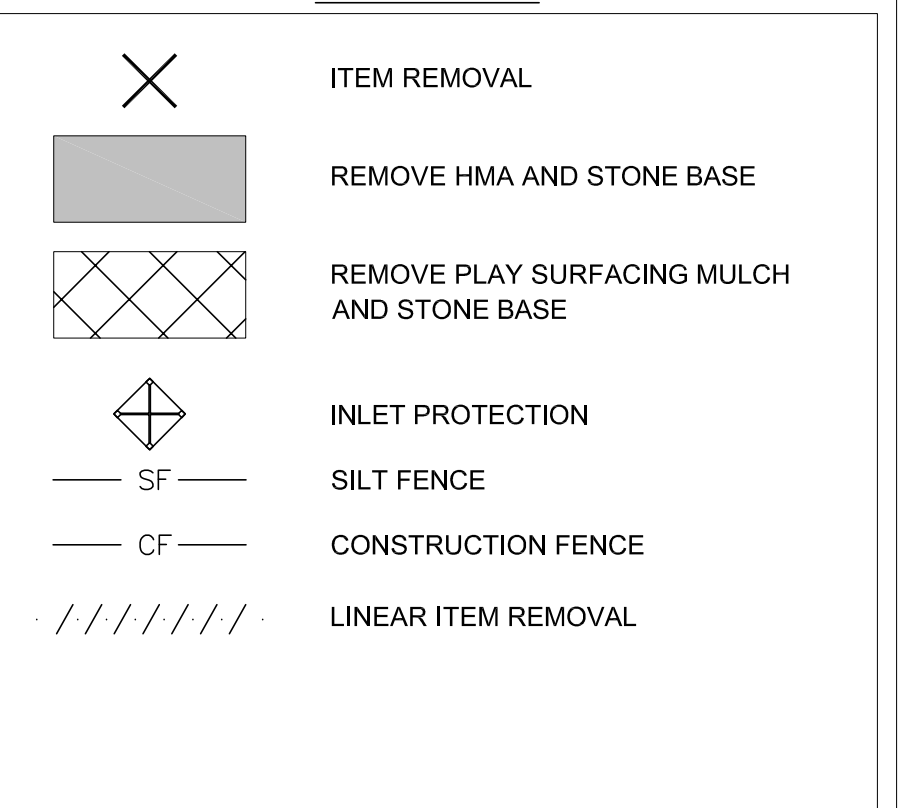

**DEMO KEY NOTES**

- 1 REMOVE PLAYGROUND STRUCTURE
- 2 SAWCUT ASPHALT
- 3 REMOVE, SALVAGE, RELOCATE BUDDY BENCH. SEE SITE PLAN
- 4 REMOVE PLAYGROUND CURB

**DEMOLITION NOTES**

1. CONTRACTOR TO PROTECT ALL EXISTING UTILITIES DURING DEMOLITION & CONSTRUCTION ACTIVITIES. WHETHER SHOWN ON THE PLANS OR NOT, UNLESS OTHERWISE SPECIFIED, ANY RELOCATION, ADJUSTMENTS, CONFLICTS, ETC. SHALL BE BROUGHT TO THE ENGINEER'S ATTENTION IMMEDIATELY. CONTRACTOR TO LOCATE ALL PUBLIC & PRIVATE UTILITIES IN THE RIGHT-OF-WAY AND SITE PRIOR TO CONSTRUCTION.
2. ALL EXISTING CURB TO REMAIN UNLESS OTHERWISE SPECIFIED, ANY CURB DAMAGED DURING DEMOLITION SHALL BE REPLACED IN KIND.
3. ALL EXISTING SIGNS & LIGHT POLES TO REMAIN AND BE PROTECTED UNLESS OTHERWISE SPECIFIED. ANY SIGNS REMOVED SHALL BE SALVAGED AND RELOCATED OR RETURNED TO OWNER.
4. ANY UTILITY ADJUSTMENTS, CONFLICTS, RELOCATIONS, ETC. REQUIRED SHALL BE COORDINATED WITH ENGINEER AND UTILITY OWNER/PROVIDER.
5. ALL EXISTING TREES TO REMAIN AND TO BE PROTECTED UNLESS OTHERWISE SPECIFIED. ANY DAMAGE TO TREES WITHIN THE VILLAGE RIGHT-OF-WAY AS A RESULT OF THIS WORK SHALL BE THE RESPONSIBILITY OF THE APPLICANT TO ADDRESS AT THE DIRECTION OF THE VILLAGE FORESTER.
6. ALL DEMOLITION AND CONSTRUCTION IN THE RIGHT-OF-WAY SHALL BE COORDINATED AND APPROVED BY THE VILLAGE OF DOWNERS GROVE. THE CONTRACTOR IS TO CONTACT THE INSPECTORS AT THE VILLAGE OF DOWNERS GROVE PRIOR TO CONSTRUCTION.
7. CONTRACTOR SHALL PROTECT ALL EXISTING ELECTRIC SERVICES DURING CONSTRUCTION AND NOTIFY ENGINEER IMMEDIATELY OF ANY CONFLICTS.
8. ALL EXISTING SHRUBS AND LANDSCAPING IN CONFLICT WITH SITE IMPROVEMENTS SHALL BE REMOVED.
9. THE CONTRACTOR WILL BE RESPONSIBLE FOR THE REPLACEMENT OF ANY DAMAGED PUBLIC/PRIVATE PROPERTY OR ROADWAY AS A RESULT OF CONSTRUCTION ON THIS SITE. THE RIGHT-OF-WAY MUST BE RESTORED TO EXISTING OR BETTER CONDITION.

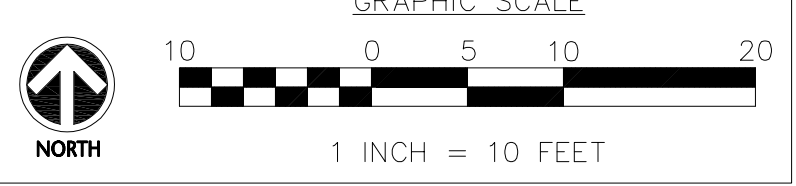

DOWNERS GROVE  
SCHOOL DISTRICT 58

**Wight**

Wight & Company  
wightco.com  
2500 North Frontage Road  
Darien, IL 60561  
P 630.969.7000  
F 630.969.7979

ISSUE FOR BID	1/19/2023	
PERMIT SET	12/02/22	
REV	DESCRIPTION	DATE

**PIERCE DOWNER  
PLAYGROUND  
IMPROVEMENTS -  
PHASE 2**

1436 GRANT STREET  
DOWNERS GROVE, IL 60515

**OVERALL EXISTING  
AND DEMOLITION PLAN**

Project Number:  
210139  
Drawn By:  
LR  
Sheet:

**L1.00**

S:\Darien\Downers Grove SD58\210139\_Pierce Downer Playground\01\11 Drawings\02 CD\PHASE II\210139-1.1.00 EXISTING CONDITIONS PH2.dwg kbuck Jan 19, 2023 9:49:48 am  
 Wight & Company All rights reserved. No part of these documents may be reproduced, stored, or transmitted in any form or by any means, electronic, mechanical, photocopying, recording or otherwise, without the prior written consent of Wight.



**LEGEND**

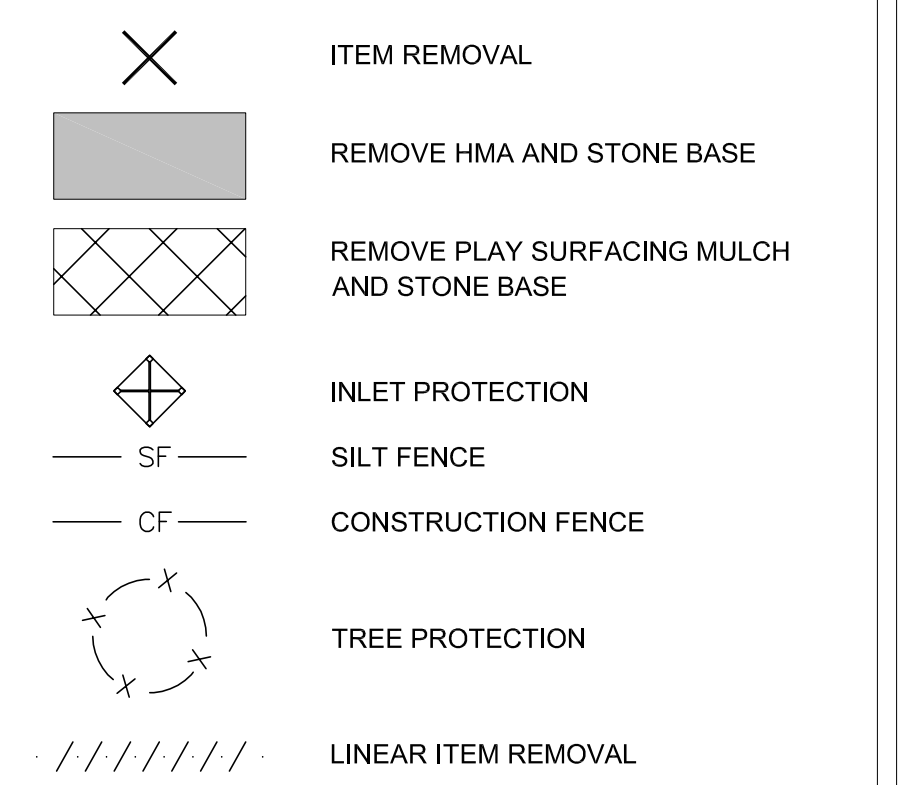

**DEMO KEY NOTES**

- 1 REMOVE PLAYGROUND STRUCTURE
- 2 SAWCUT ASPHALT
- 3 REMOVE, SALVAGE, RELOCATE BUDDY BENCH. SEE SITE PLAN
- 4 REMOVE PLAYGROUND CURB

**DEMOLITION NOTES**

1. CONTRACTOR TO PROTECT ALL EXISTING UTILITIES DURING DEMOLITION & CONSTRUCTION ACTIVITIES. WHETHER SHOWN ON THE PLANS OR NOT, UNLESS OTHERWISE SPECIFIED, ANY RELOCATION, ADJUSTMENTS, CONFLICTS, ETC. SHALL BE BROUGHT TO THE ENGINEER'S ATTENTION IMMEDIATELY. CONTRACTOR TO LOCATE ALL PUBLIC & PRIVATE UTILITIES IN THE RIGHT-OF-WAY AND SITE PRIOR TO CONSTRUCTION.
2. ALL EXISTING CURB TO REMAIN UNLESS OTHERWISE SPECIFIED, ANY CURB DAMAGED DURING DEMOLITION SHALL BE REPLACED IN KIND.
3. ALL EXISTING SIGNS & LIGHT POLES TO REMAIN AND BE PROTECTED UNLESS OTHERWISE SPECIFIED. ANY SIGNS REMOVED SHALL BE SALVAGED AND RELOCATED OR RETURNED TO OWNER.
4. ANY UTILITY ADJUSTMENTS, CONFLICTS, RELOCATIONS, ETC. REQUIRED SHALL BE COORDINATED WITH ENGINEER AND UTILITY OWNER/PROVIDER.
5. ALL EXISTING TREES TO REMAIN AND TO BE PROTECTED UNLESS OTHERWISE SPECIFIED. ANY DAMAGE TO TREES WITHIN THE VILLAGE RIGHT-OF-WAY AS A RESULT OF THIS WORK SHALL BE THE RESPONSIBILITY OF THE APPLICANT TO ADDRESS AT THE DIRECTION OF THE VILLAGE FORESTER.
6. ALL DEMOLITION AND CONSTRUCTION IN THE RIGHT-OF-WAY SHALL BE COORDINATED AND APPROVED BY THE VILLAGE OF DOWNERS GROVE. THE CONTRACTOR IS TO CONTACT THE INSPECTORS AT THE VILLAGE OF DOWNERS GROVE PRIOR TO CONSTRUCTION.
7. CONTRACTOR SHALL PROTECT ALL EXISTING ELECTRIC SERVICES DURING CONSTRUCTION AND NOTIFY ENGINEER IMMEDIATELY OF ANY CONFLICTS.
8. ALL EXISTING SHRUBS AND LANDSCAPING IN CONFLICT WITH SITE IMPROVEMENTS SHALL BE REMOVED.
9. THE CONTRACTOR WILL BE RESPONSIBLE FOR THE REPLACEMENT OF ANY DAMAGED PUBLIC/PRIVATE PROPERTY OR ROADWAY AS A RESULT OF CONSTRUCTION ON THIS SITE. THE RIGHT-OF-WAY MUST BE RESTORED TO EXISTING OR BETTER CONDITION.

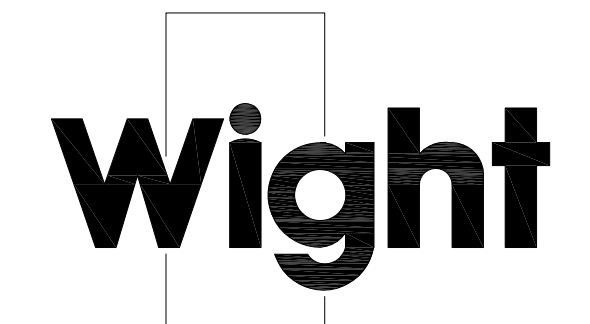
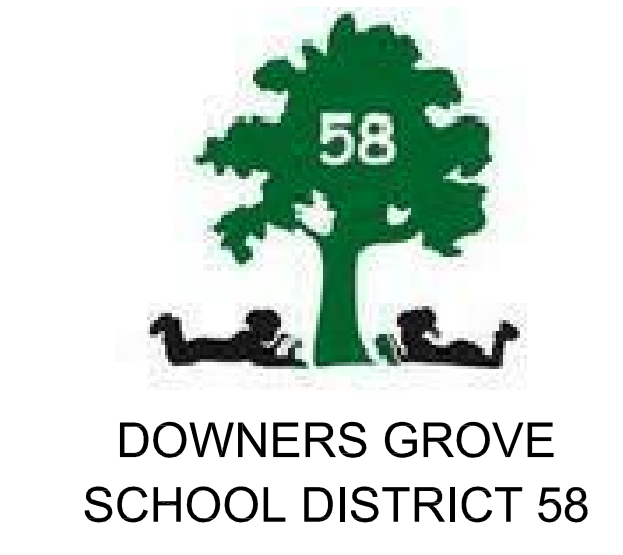

Wight & Company  
 wightco.com  
 2500 North Frontage Road  
 Darien, IL 60561  
 P 630.969.7000  
 F 630.969.7979

REV	DESCRIPTION	DATE
	ISSUE FOR BID	1/19/2023
	PERMIT SET	12/02/22

**PIERCE DOWNER PLAYGROUND IMPROVEMENTS - PHASE 2**  
 1436 GRANT STREET  
 DOWNERS GROVE, IL 60515

**EXISTING CONDITIONS AND DEMOLITION PLAN**

Project Number:  
 210139  
 Drawn By:  
 LR  
 Sheet:

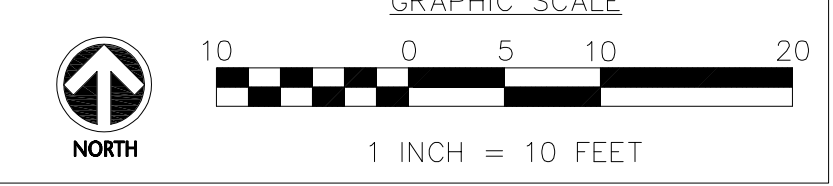



**L1.01**

S:\Darien\Downers Grove SD58\210139\_Pierce Downer Playground\01\11 Drawings\02 CD\PHASE\02 CD\PHASE II\210139-L2.00 SITE PLAN PH2.dwg Iremitz Jan 19, 2023 10:28:01 am  
 Wight & Company All rights reserved. No part of these documents may be reproduced, stored, or transmitted in any form or by any means, electronic, mechanical, photocopying, recording or otherwise, without the prior written consent of Wight.

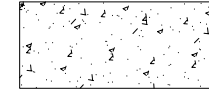
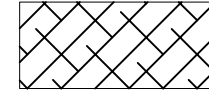

**LEGEND**

-  PCC SIDEWALK AND STONE BASE
-  POURED IN PLACE PLAYGROUND SURFACE
-  PROPERTY LINE

**SITE KEY NOTES**

- 1 PLAYGROUND CURB
- 2 THICKENED EDGE CONCRETE
- 3 SCORE JOINT
- 4 PLAYGROUND RAMP
- 5 RELOCATED BUDDY BENCH
- 6 OODLE SWING. PLAY EQUIPMENT PURCHASED BY OWNER AND INSTALLED BY CONTRACTOR.
- 7 MAIN PLAYGROUND STRUCTURE. PLAY EQUIPMENT PURCHASED BY OWNER AND INSTALLED BY CONTRACTOR.
- 8 WE-SAW. PLAY EQUIPMENT PURCHASED BY OWNER AND INSTALLED BY CONTRACTOR.
- 9 BRICK PAVER PROVIDED BY OWNER AND INSTALLED BY CONTRACTOR.

**SITE PLAN NOTES**

1. ALL LAYOUT FOR SITE IMPROVEMENTS SHALL BE COMPLETED BY A PROFESSIONAL LAND SURVEYOR HIRED BY THE CONTRACTOR. LAYOUT SHALL BE COMPLETED USING THE ELECTRONIC CAD FILES PROVIDED BY THE ENGINEER. NO ADDITIONAL PAYMENT WILL BE MADE FOR ADJUSTMENT NECESSARY TO CONSTRUCT THE WORK AS DRAWN.
2. CONTRACTOR SHALL OBTAIN APPROVAL OF LAYOUT FROM THE OWNER'S REPRESENTATIVE PRIOR TO CONSTRUCTION. NO ADDITIONAL PAYMENT SHALL BE MADE TO CORRECT WORK IF CONSTRUCTED INCORRECTLY PRIOR TO APPROVAL OF LAYOUT.
3. CONTRACTOR IS RESPONSIBLE FOR MAINTAINING ALL LAYOUT MARKINGS. NO ADDITIONAL PAYMENT WILL BE MADE TO REPLACE MARKINGS.
4. ALL DIMENSIONS, CURB RADII, AND ELEVATIONS REFER TO THE BACK OF CURB WHERE CURB SHOWN UNLESS OTHERWISE SHOWN. ALL WALL DIMENSIONS ARE TO THE FACE OF WALL UNLESS OTHERWISE SHOWN. ALL PAVEMENT DIMENSIONS ARE TO THE EDGE OF PAVEMENT UNLESS OTHERWISE SHOWN. COORDINATES ARE TO THE BACK OF CURB, CENTER OF STRUCTURE, OR AS SHOWN.
5. ALL RADII SHALL BE SMOOTH AND CONTINUOUS AND NOT SEGMENTED. CONTRACTOR TO PROVIDE STAKES A MINIMUM OF EVERY 10 FEET WHERE RADIUS POINTS ARE NOT ACCESSIBLE.
6. ADJUSTMENTS TO STAKE LOCATIONS DUE TO DISCREPANCIES BETWEEN COORDINATES AND DIMENSIONS ARE CONSIDERED INCIDENTAL TO THE WORK.
7. CONTRACTOR RESPONSIBLE TO TAKE DELIVERY, VERIFY CONDITION AND COMPLETENESS, ASSEMBLE AND INSTALL ALL MATERIALS AND FURNISHINGS PER MANUFACTURER'S INSTRUCTIONS.
8. PLACE CONTROL AND EXPANSION JOINTS WHERE INDICATED ON PLANS AND DETAILS FOR CONCRETE WORK. WHERE JOINTS ARE NOT SHOWN, PLACE CONTROL JOINTS IN SPACING TO MATCH PAVEMENT WIDTH OR MAXIMUM OF 10 FEET ON CENTER. EXPANSION JOINTS SHALL BE A MAXIMUM OF 30 FEET ON CENTER AND BETWEEN ALL POURS AND EXISTING CONCRETE OR WALLS.
9. ANY CHANGE TO THE SITE PLAN DURING DESIGN OR IN FIELD DURING CONSTRUCTION MUST BE SUBMITTED IN WRITING TO THE ENGINEER AND VILLAGE OF DOWNERS GROVE.
10. ALL DISTURBED AREAS ON-SITE AND IN THE RIGHT-OF-WAY SHALL BE RESTORED TO EXISTING CONDITION. ALL ITEMS DISTURBED SHALL BE REPLACED INCLUDING ALL LANDSCAPING, CURB, SIDEWALK, PAVEMENT, ETC.
11. ALL EXISTING TREES TO REMAIN AND TO BE PROTECTED UNLESS OTHERWISE NOTED.

CATCH BASIN 4" DIA.  
 TY. A W/ TY. 1 D.L. F&G  
 RIM= 740.76  
 INV= 735.62 (SE, SW)  
 INV= 737.65 (S)

CATCH BASIN  
 RIM= 740.31  
 INV= 736.25 (NE)  
 INV= 736.74 (NE,SE)  
 INV=736.66 (SW)

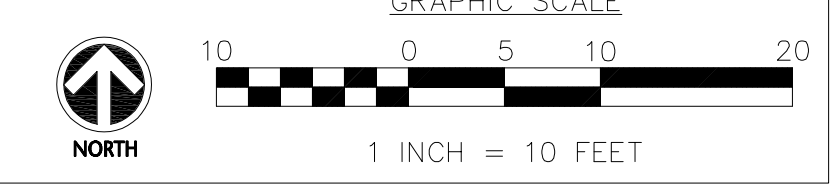

DOWNERS GROVE  
 SCHOOL DISTRICT 58

**Wight**

Wight & Company  
 wightco.com  
 2500 North Frontage Road  
 Darien, IL 60561  
 P 630.969.7000  
 F 630.969.7979

ISSUE FOR BID	1/19/2023	
PERMIT SET	12/02/22	
REV	DESCRIPTION	DATE

**PIERCE DOWNER  
 PLAYGROUND  
 IMPROVEMENTS -  
 PHASE 2**  
 1436 GRANT STREET  
 DOWNERS GROVE, IL 60515

**SITE PLAN**

Project Number:  
 210139  
 Drawn By:  
 LR  
 Sheet:

**L2.00**

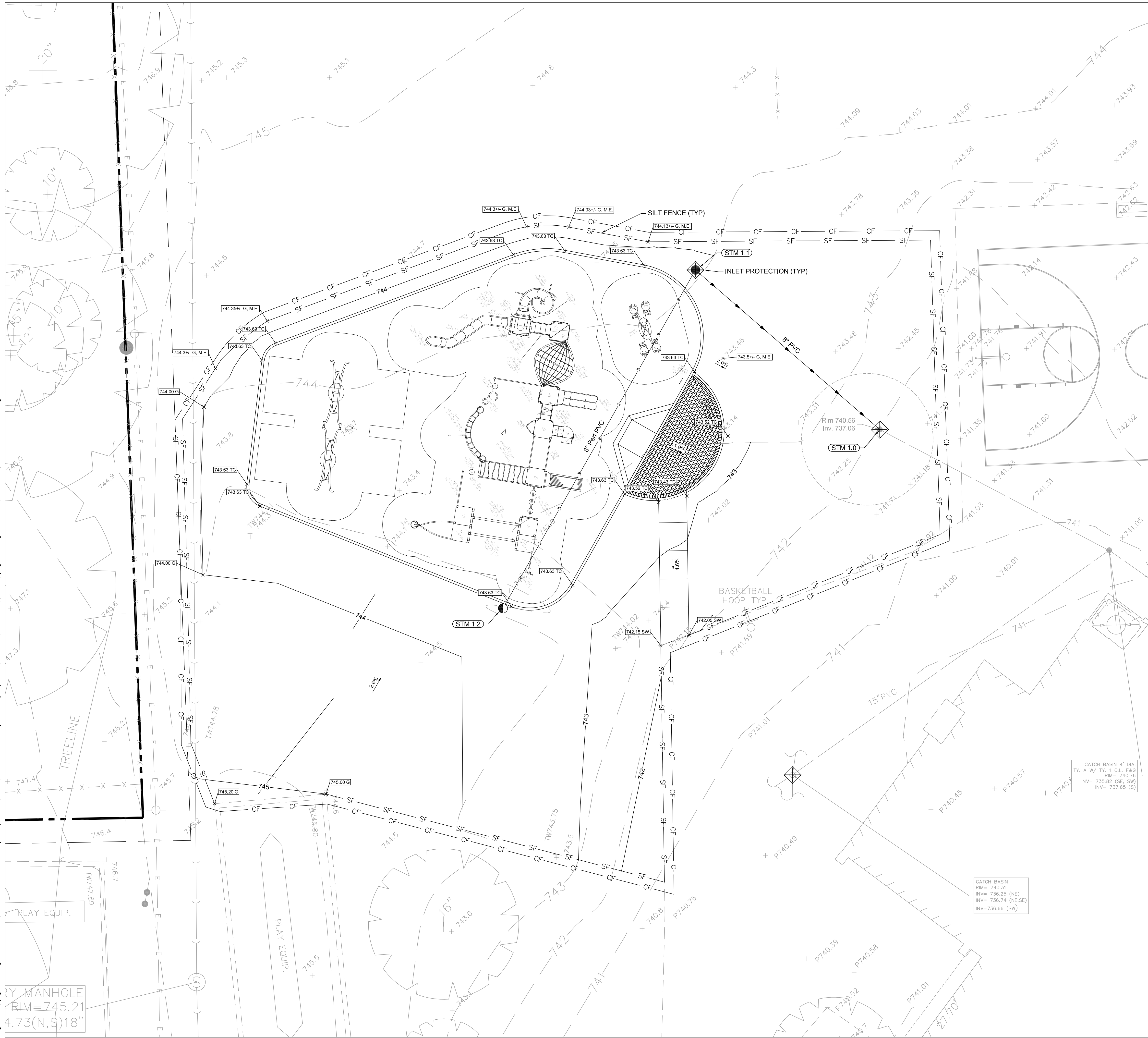

**LEGEND**

ME	MATCH EXISTING ELEVATION
HP	HIGH POINT
11.77 P	TOP OF PAVEMENT ELEVATION
11.77 G	GROUND ELEVATION
11.77 SW	TOP OF SIDEWALK ELEVATION
11.77 RM	RIM ELEVATION
11.77 PS	PLAY SURFACE
-745-	EXISTING CONTOUR LINE
-745-	PROPOSED CONTOUR LINE
2.0%	SLOPE/FLOW DIRECTION
→	STORM SEWER
←	UNDERDRAIN
●	CATCH BASIN
◇	INLET PROTECTION
SF	SILT FENCE
→	OVERLAND FLOW ROUTE

**GRADING NOTES**

- CONTRACTOR TO VERIFY ALL EXISTING UTILITY LOCATIONS, SIZES, SLOPES, INVERTS, ETC. AND CONTACT ENGINEER IMMEDIATELY IF THERE ARE ANY CONFLICTS/DISCREPANCIES.
- CONTRACTOR TO PROTECT ALL EXISTING UTILITIES.
- ALL EXISTING UTILITY STRUCTURES SHALL BE ADJUSTED AS NECESSARY TO MATCH FINISH GRADE. ALL EXISTING UTILITY STRUCTURES REQUIRING ADJUSTMENT OR RECONSTRUCTION SHALL BE COMPLETED BY THE CONTRACTOR TO THE SATISFACTION OF THE UTILITY OWNER. ADJUSTMENTS AND/OR RECONSTRUCTIONS NOT CALLED FOR ON THE PLANS SHALL BE CONSIDERED INCIDENTAL TO THE CONTRACT. NO MORE THAN A TOTAL OF 12 INCHES OF ADJUSTING RINGS AND/OR 2 ADJUSTING RINGS SHALL BE ALLOWED.
- ALL SITE WORK SHALL BE IN CONFORMANCE WITH THE ILLINOIS ACCESSIBILITY CODE AND WITH THE AMERICANS WITH DISABILITIES ACT.
- SLOPES BETWEEN SPOT ELEVATIONS ON PATHWAYS SHALL BE CONSISTENT.
- MAXIMUM SLOPE ON ALL PAVED SURFACES IS 1:20 (5%). RAMPS SHALL NOT EXCEED A RUNNING SLOPE OF 1:12 (8.33%).
- ALL SURFACES SHALL BE GRADED FOR POSITIVE DRAINAGE. MAXIMUM CROSS-SLOPE ON ANY WALK OR RAMPS SHALL BE 2% IN DIRECTION INDICATED. IF NO DIRECTION IS INDICATED, GRADE FOR POSITIVE DRAINAGE AWAY FROM WALLS, COLUMNS, STEPS, AND STRUCTURES.
- ALL ACCESSIBLE PARKING SPACES AND LOADING ZONES SHALL HAVE A MAXIMUM SLOPE OF 2% IN ANY DIRECTION.
- AVOID EXCESSIVE FILL IN CRITICAL ROOT ZONES. SEE SPECIFICATIONS. FEATHER NEWLY GRADED AREAS INTO EXISTING GRADE.
- TOPSOIL IN AREAS DESIGNATED FOR PAVING SHALL BE STRIPPED AND RESPREAD IN ACCORDANCE WITH GRADING PLAN. HAUL OFF SITE AND LEGALLY DISPOSE OF UNSUITABLE OR EXCESS EXCAVATED MATERIAL.
- TOPSOIL IN AREAS OF NEWLY CREATED BERMS SHALL BE STRIPPED AND STOCKPILED. CONSTRUCT BERM USING ON SITE FILL MATERIAL OR IMPORTED MATERIAL AS DIRECTED. RESPREAD TOPSOIL IN ACCORDANCE WITH GRADING PLAN AND SPECIFICATIONS.
- TOPSOIL SHALL BE IMPORTED AS NEEDED AND SPREAD AT SPECIFIED DEPTHS TO ACHIEVE FINAL GRADE. GRANULAR FILL WILL NOT BE ACCEPTED UNDER TURF OR PLANTING AREAS.
- PROMPTLY NOTIFY OWNER'S REPRESENTATIVE IS UNSATISFACTORY SUB-GRADE MATERIALS ARE DISCOVERED.
- OBTAIN LANDSCAPE ARCHITECT'S REVIEW OF FINE GRADING PRIOR TO SEEDING OPERATIONS.
- REFER TO SPECIFICATIONS FOR ADDITIONAL CONDITIONS, STANDARDS, AND NOTES.
- ANY SOIL STOCKPILES SHALL BE PROTECTED WITH DOUBLE ROW OF SILT FENCE COIR ROLL AROUND PERIMETER.
- ANY DAMAGE TO TREES WITHIN THE VILLAGE RIGHT OF WAY AS A RESULT OF THIS WORK SHALL BE THE RESPONSIBILITY OF THE APPLICANT TO ADDRESS AT THE DIRECTION OF THE VILLAGE FORESTER.
- A FINAL GRADING SURVEY IS REQUIRED AT THE COMPLETION OF THE PROJECT, INCLUDING AN ELECTRONIC COPY. IT SHALL INCLUDE, BUT IS NOT LIMITED TO, THE FOLLOWING ITEMS:
  - ALL NEW IMPERVIOUS AREAS INCLUDING THOSE MADE OF CONCRETE, ASPHALT, AND BRICK PAVER.
  - AS-BUILT LOCATION AND AS-BUILT VOLUME OF ANY PCBMP.

CATCH BASIN 4' DIA.  
TY. A W/ TY. 1 D.I. F&G  
RM= 740.31  
INV= 736.25 (NE)  
INV= 735.92 (SE, SW)  
INV= 737.65 (S)

CATCH BASIN  
RM= 740.31  
INV= 736.25 (NE)  
INV= 736.74 (NE,SE)  
INV=736.66 (SW)

GRAPHIC SCALE

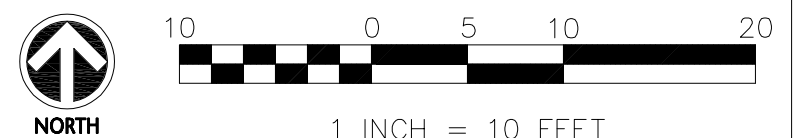

DOWNERS GROVE  
SCHOOL DISTRICT 58

**Wight**

Wight & Company  
wightco.com  
2500 North Frontage Road  
Darien, IL 60561  
P 630.969.7000  
F 630.969.7979

ISSUE FOR BID	1/19/2023	
PERMIT SET	12/02/22	
REV	DESCRIPTION	DATE

**PIERCE DOWNER  
PLAYGROUND  
IMPROVEMENTS -  
PHASE 2**

1436 GRANT STREET  
DOWNERS GROVE, IL 60515

**GRADING AND DRAINAGE  
PLAN**

Project Number:  
210139  
Drawn By:  
LR  
Sheet:

**L3.00**

S:\Darien\Downers Grove SD58\210139\_Pierce Downer Playground\01\11 Drawings\02 CD\PHASE II\210139-L3.01 UTILITY PROFILE PLAN.dwg kbuck Jan 19, 2023 9:50:05 am  
 Wight © Copyright All rights reserved. No part of these documents may be reproduced, stored, or transmitted in any form or by any means, electronic, mechanical, photocopying, recording or otherwise, without the prior written consent of Wight.



DOWNERS GROVE  
SCHOOL DISTRICT 58

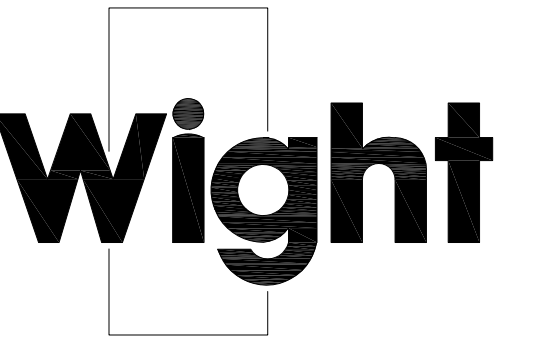

Wight & Company  
wightco.com

2500 North Frontage Road  
Darien, IL 60561

P 630.969.7000  
F 630.969.7979

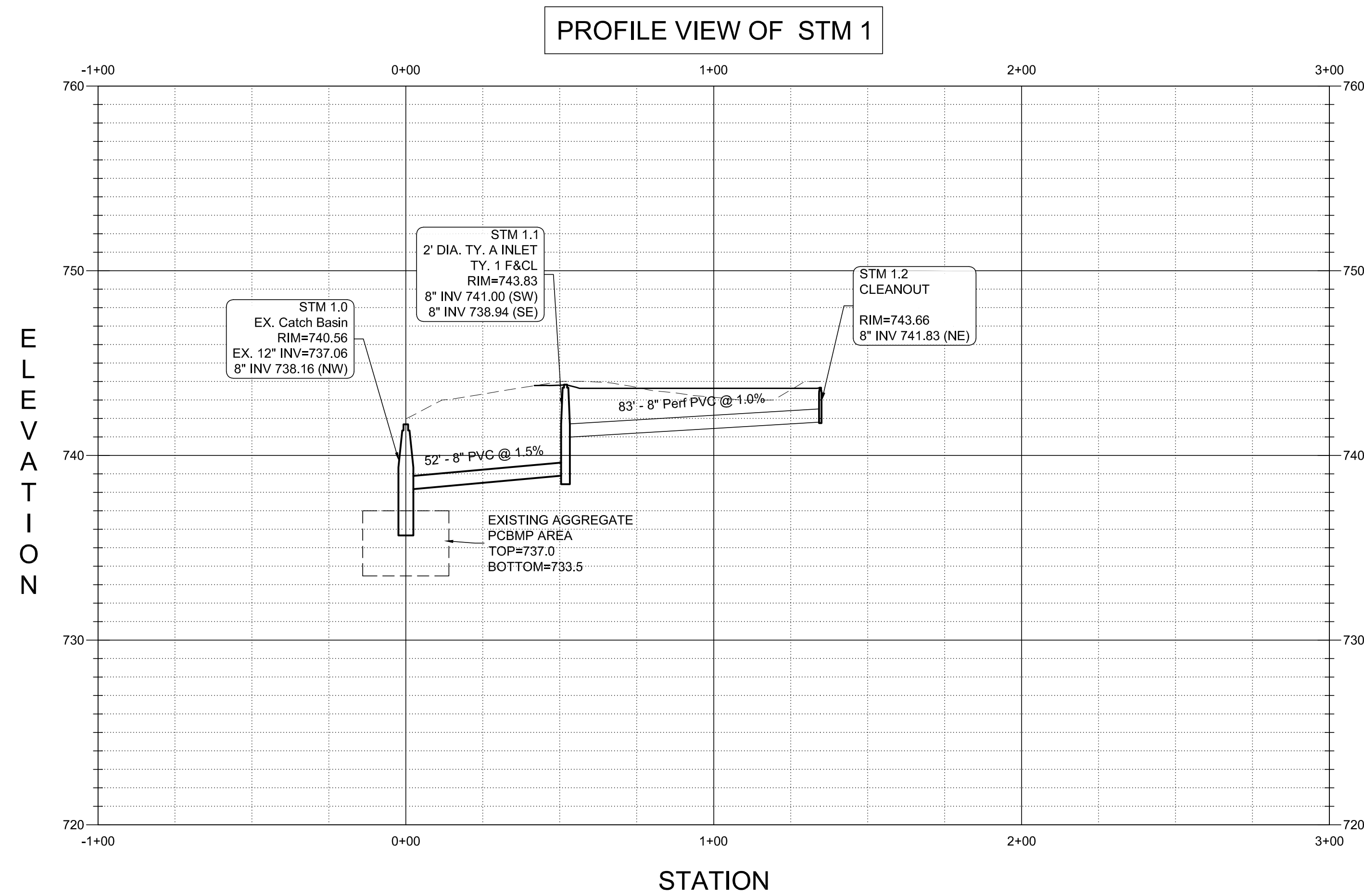

**NOTES:**

1. ALL EXISTING WATER, SEWER, ETC. SHOWN IS APPROXIMATE LOCATION AND BASED UPON BEST AVAILABLE INFORMATION. CONTRACTOR TO LOCATE IN THE FIELD PRIOR TO CONSTRUCTION. CONTRACTOR TO COORDINATE ALL RE-ROUTING, LOWERING AND OR NEW UTILITY SERVICES WITH MEP PLANS & UTILITY PROVIDER DUE TO CONFLICTS AS SHOWN ON THE PROFILES.
2. FOLLOW ALL WATER MAIN SEPARATION REQUIREMENTS FROM SHEET C0.01 GENERAL NOTES. ALL IEPA REQUIREMENTS AND STANDARD SPECIFICATIONS FOR WATER AND SEWER CONSTRUCTION IN ILLINOIS (LATEST EDITION) SHALL BE ADHERED TO.
3. ALL WATER MAIN AND WATER SERVICES SHALL HAVE A MINIMUM OF 5.5 FEET OF COVER.
4. ANY NEW DRY UTILITIES INSTALLED (TELE/ELEC/CABLE/GAS) SHALL AVOID PROPOSED SANITARY, STORM AND WATER UTILITIES DURING INSTALLATION. DRY UTILITIES SHALL BE SET ABOVE OR BELOW SAID UTILITIES.

HORIZONTAL SCALE - 1:30  
VERTICAL SCALE - 1:5

ISSUE FOR BID	1/19/2023
PERMIT SET	12/02/22
REV	DESCRIPTION DATE

**PIERCE DOWNER  
PLAYGROUND  
IMPROVEMENTS -  
PHASE 2**

1436 GRANT STREET  
DOWNERS GROVE, IL 60515

**UTILITY PROFILE PLAN**

Project Number:  
210139  
Drawn By:  
DE  
Sheet:

**L3.01**

S:\Darien\Downers Grove SD58\210139\_Pierce Downer Playground\01\11 Drawings\02 CD\PHASE II\210139-L4.00 LANDSCAPE PLAN PH2.dwg k buck Jan 19, 2023 9:50:11 am  
 Wight © Copyright All rights reserved. No part of these documents may be reproduced, stored, or transmitted in any form or by any means, electronic, mechanical, photocopying, recording or otherwise, without the prior written consent of Wight.

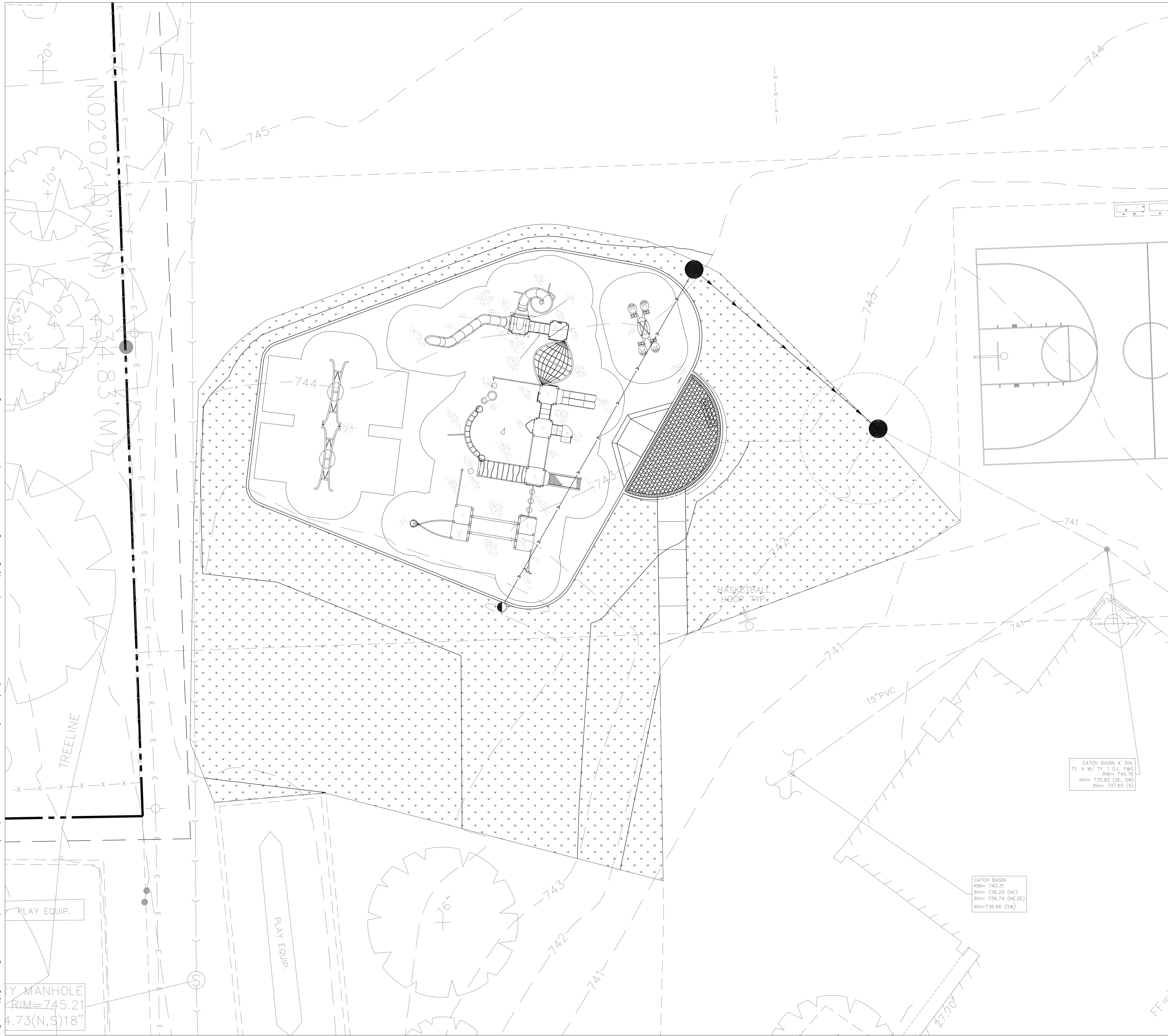

**LEGEND**

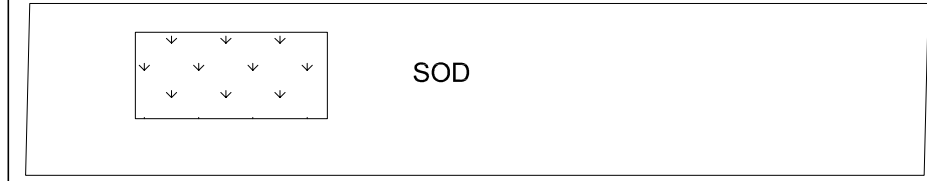

**LANDSCAPE NOTES**

- SOD LIMIT LINE IS APPROXIMATE. RESTORE TO LIMITS OF DISTURBANCE. ALL AREAS DISTURBED BY CONSTRUCTION SHALL BE RESTORED WITH TOPSOIL (MIN. 6" DEPTH), FERTILIZER, AND SOD AS SHOWN.
- CONTRACTOR RESPONSIBLE TO RESTORE ALL AREAS DISTURBED BY CONSTRUCTION, OUTSIDE SCOPE LIMIT, TO EXISTING CONDITION.
- THE CONTRACTOR SHALL PROTECT ALL TREES SHOWN ON THE PLANS. CONTRACTOR SHALL INSTALL TREE PROTECTION FENCING AS SHOWN ON PLANS AND DETAILS PRIOR TO BEGINNING WORK.
- THE CONTRACTOR WILL MAKE NO SUBSTITUTIONS WITHOUT PRIOR WRITTEN CONSENT BY THE LANDSCAPE ARCHITECT. THE CONTRACTOR WILL SUBMIT ANY SUBSTITUTIONS IN WRITING TO THE LANDSCAPE ARCHITECT.
- ALL PLANTING TECHNIQUES AND METHODS SHALL BE CONSISTENT WITH THE LATEST EDITION OF "AMERICAN STANDARD FOR NURSERY STOCK" AND AS DETAILED ON THESE DRAWINGS. DISCREPANCIES SHALL BE REPORTED IMMEDIATELY TO THE LANDSCAPE ARCHITECT.
- TREES PLACED IN TURF AREAS WILL HAVE 6" DIA. MULCH RING WITH 3" DEEP SPADE CUT EDGE.
- TREES SHALL BE INSTALLED A MINIMUM OF 10' HORIZONTALLY FROM NEAREST LIGHT POLE.
- TREES SHALL BE INSTALLED A MINIMUM OF 5' HORIZONTALLY FROM UNDERGROUND ELECTRICAL FEEDERS, SANITARY SEWERS, SANITARY SERVICES, WATER MAINS, AND WATER SERVICES.
- TREES SHALL BE INSTALLED A MINIMUM OF 10' HORIZONTALLY FROM UTILITY STRUCTURES AND APPURTENANCES, INCLUDING, BUT NOT LIMITED TO MANHOLES, VALVE VAULTS, VALVE BOXES, AND FIRE HYDRANTS.
- ANY AREA COMPACTED BY CONSTRUCTION TRAFFIC SHALL BE FILLED OR RESTORED TO ALLOW FOR SUITABLE PLANTING CONDITIONS.
- THE CROWNS AND ROOTS OF TREES WHICH ARE TO BE PRESERVED IN THE PROJECT AREA, BUT WHICH COULD BE NEGATIVELY AFFECTED DURING THE CONSTRUCTION PROCESS, SHALL BE PRUNED BY A QUALIFIED ARBORIST ACCORDING TO THE TREE PRUNING STANDARDS SET BY ANSI 2100 CODE.
- USE MWWD BIOSOLIDS FOR AMENDING TOPSOIL.
- CONTRACTOR SHALL INCLUDE DAILY WATERING FOR ALL SOD, FOR A 3-WEEK DURATION.
- CONTRACTOR RESPONSIBLE FOR MAINTAINING EXISTING AND NEW TURF TO VILLAGE ORDINANCE STANDARDS DURING CONSTRUCTION ACTIVITIES. THIS INCLUDES MOWING, WEED WHIPPING & TRASH REMOVAL.
- EXISTING TREES TO REMAIN SHALL HAVE A 6" DIAMETER MULCH RING INSTALLED WITH 3" DEEP SPADE CUT EDGE.
- CONTRACTOR RESPONSIBLE TO RESTORE CONSTRUCTION ENTRANCE WITH SOD.



DOWNERS GROVE  
SCHOOL DISTRICT 58

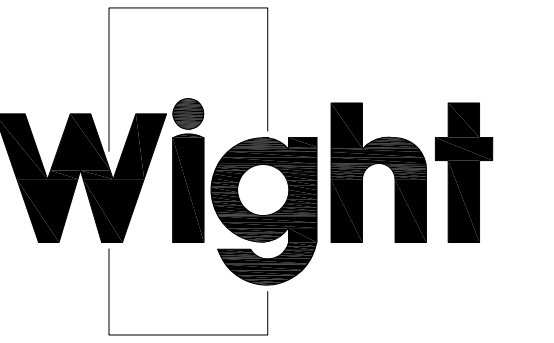

Wight & Company  
wightco.com

2500 North Frontage Road  
Darien, IL 60561

P 630.969.7000  
F 630.969.7979

ISSUE FOR BID 1/19/2023

PERMIT SET 12/02/22

REV	DESCRIPTION	DATE
-----	-------------	------

**PIERCE DOWNER  
PLAYGROUND  
IMPROVEMENTS -  
PHASE 2**

1436 GRANT STREET  
DOWNERS GROVE, IL 60515

**LANDSCAPE PLAN**

Project Number:  
210139  
Drawn By:  
LR  
Sheet:

**L4.00**

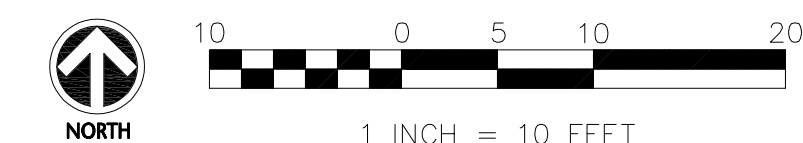



S:\Darien\Downers Grove SD58\210139\_Pierce Downer Playground\01\11 Drawings\02 CD\PHASE\02 CD\PHASE II\210139-L5.00 DETAILS PH2.dwg k buck Jan 19, 2023 9:50:15 am  
 Wight © Copyright All rights reserved. No part of these documents may be reproduced, stored, or transmitted in any form or by any means, electronic, mechanical, photocopying, recording or otherwise, without the prior written consent of Wight.

**1** SILT FENCE  
 SCALE: NTS

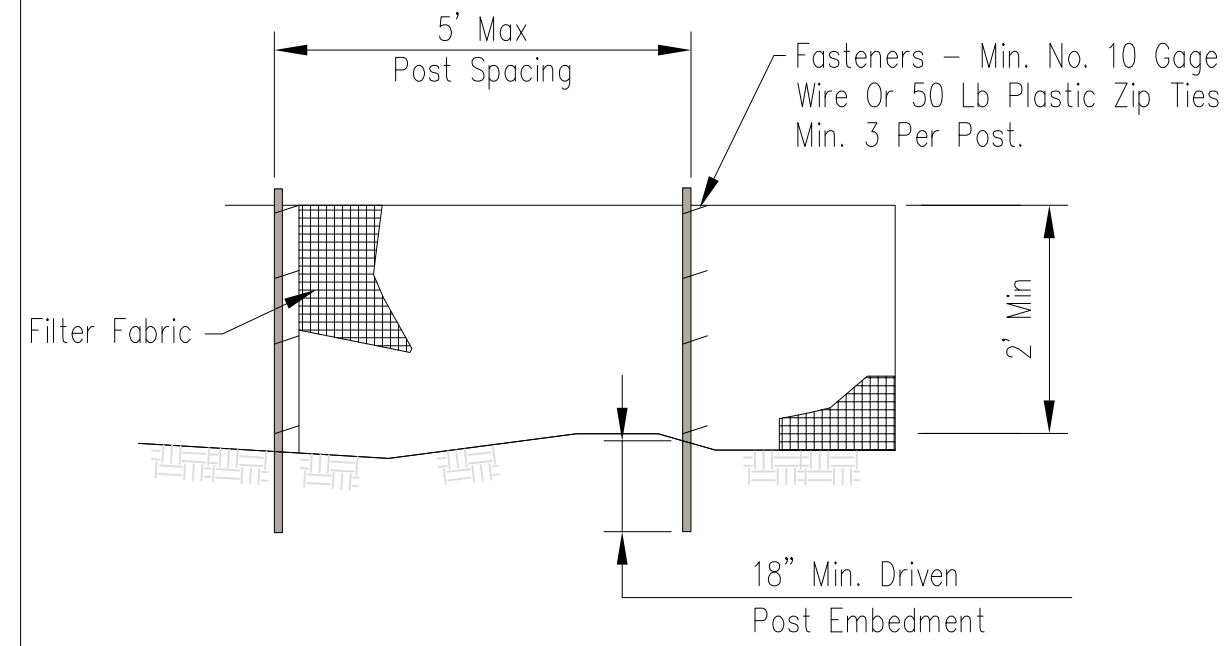

ELEVATION

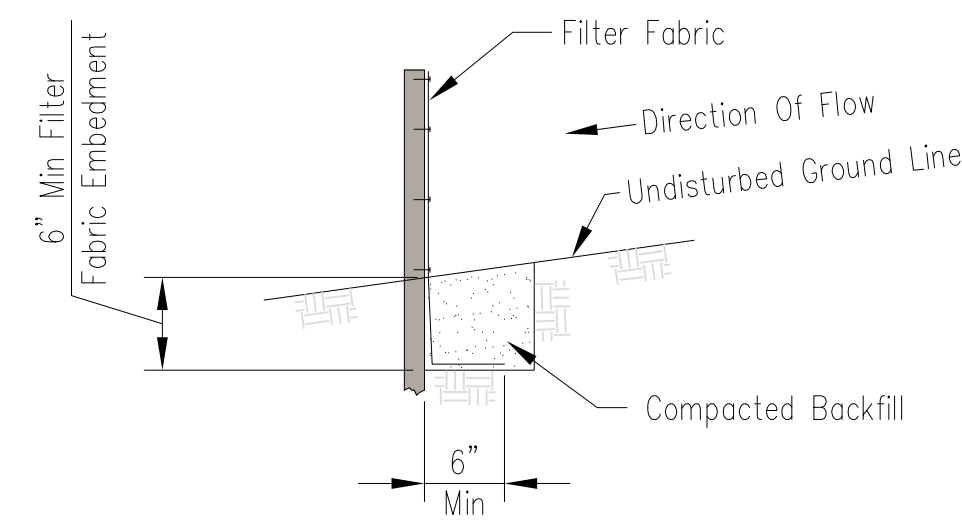

FABRIC ANCHOR DETAIL

- NOTES:  
 1. Temporary silt fence shall be installed prior to any grading work in the area to be protected. Fence shall be maintained throughout the construction period and removed in conjunction with the final grading and site stabilization.  
 2. Filter fabric shall meet the requirements of material specification 592 Geotextile Table 1 or 2, Class I with equivalent opening size of at least 30 for nonwoven and 50 for woven.  
 3. Fence posts shall be either wood post with a minimum cross-sectional area of 1.5" X 1.5" or a standard steel post.  
 4. When splices are necessary make splice at post according to splice detail. Place the end post of the second fence inside the end post of the first fence. Rotate both posts together at least 180 degrees to create a tight seal with the fabric material. Cut the fabric near the bottom of the posts to accommodate the 6 inch flap. Then drive both posts and bury the flap. Compact backfill well.

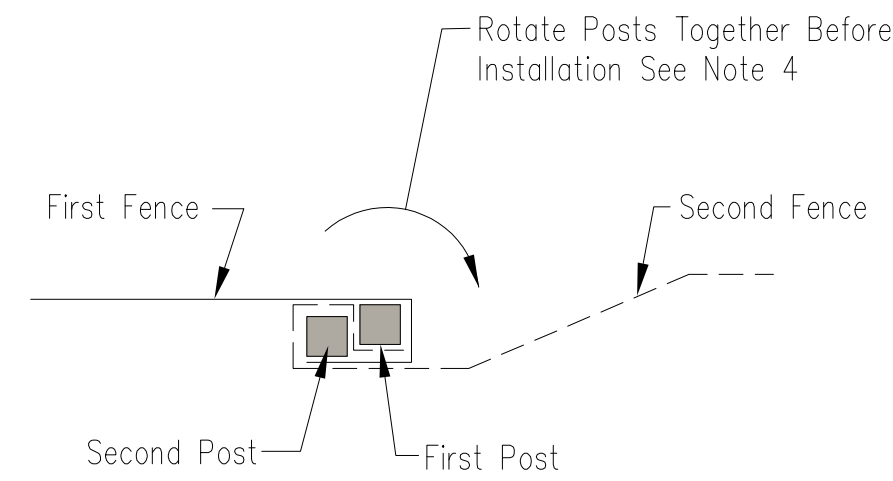

SPLICE DETAIL—PLAN VIEW

Design	8/7/14
Drawn	M. QUAINES
Checked	
Approved	

**SILT FENCE**

United States Department of Agriculture	USDA
Natural Resources Conservation Service	

File No. IL-ENG-49  
 Drawing No. \_\_\_\_\_  
 Page 1 of 1  
 Sheet of \_\_\_\_\_

**2** DROP INLET PROTECTION FOR STRUCTURES IN IMPERVIOUS AREAS ONLY  
 SCALE: NTS

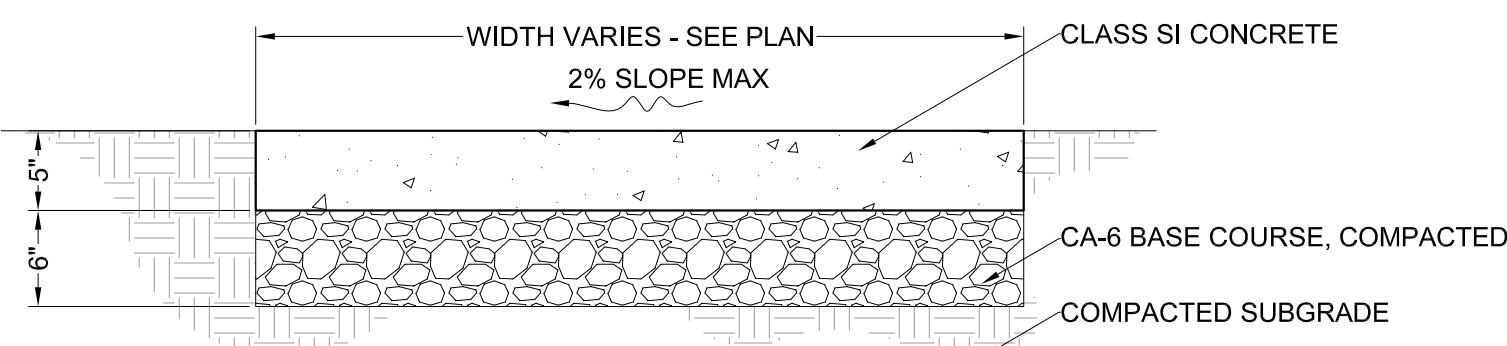

- NOTES:  
 1. ALL SIDEWALKS SHALL BE CONSTRUCTED WITH IDOT CLASS SI CONCRETE, NOT LESS THAN 3500 P.S.I. CONCRETE AT 14 DAYS.  
 2. SIDEWALK THICKNESS CROSS DRIVEWAY SHALL BE A MINIMUM 8".  
 3. REFER TO EXPANSION JOINT DETAIL.  
 4. THE TRANSVERSE JOINTS SHALL EXTEND TO 1/4 THE DEPTH OF THE SIDEWALK, SHALL NOT BE MORE THAN 1/4" IN WIDTH, AND SHALL BE EDGED HAVING A 1/4 INCH RADIUS. NO SLAB SHALL BE LONGER THAN 6 FEET NOR LESS THAN 4 FEET ON ANY ONE SIDE.

**6** CONCRETE PAVEMENT  
 SCALE: 1"=1'-0"

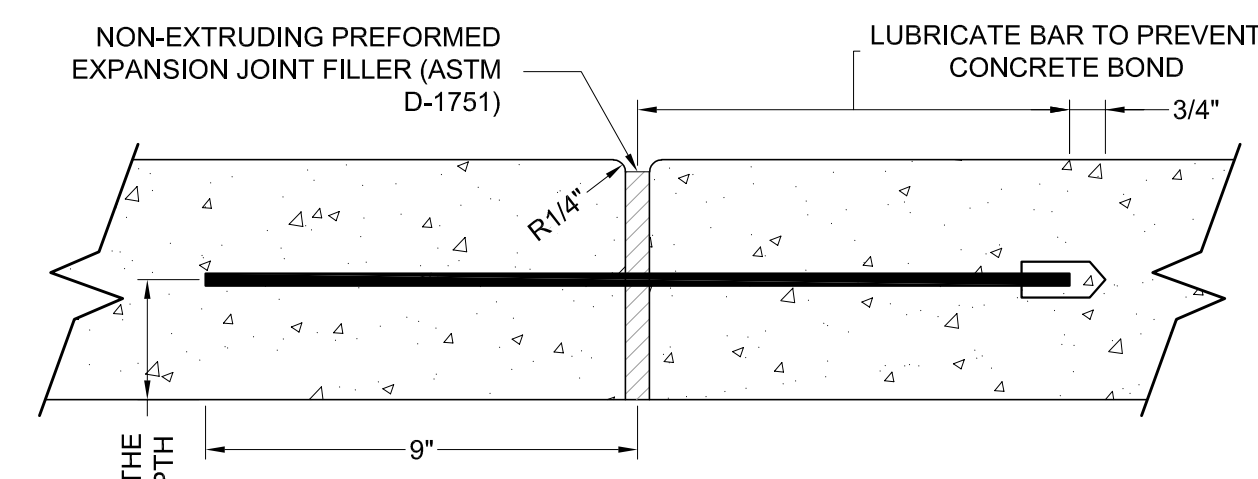

- NOTES:  
 1. PREFORMED FLEXIBLE FOAM EXPANSION JOINT FILLER NOT ACCEPTED.  
 2. EACH EXPANSION JOINT SHALL HAVE (2) 3/8" EPOXY COATED DOWEL BARS, 18" LONG AND PROPERLY LUBRICATED, PLACED AT MID DEPTH.  
 3. EXPANSION JOINTS 1" THICK SHALL BE WHERE PROPOSED CONCRETE MEETS EXISTING CONCRETE, AT 50 FT INTERVALS FOR HAND POURS AND 100 FT INTERVALS FOR SLIP OR MONOLITHIC POURS.  
 4. EXPANSION JOINTS, 1/2" THICK SHALL BE AT EVERY P.C. & P.T. OF CURVATURE, 5 FT EACH SIDE OF STRUCTURES, AND AT END OF POURS.  
 5. PREFORMED EXPANSION JOINT 1/2" THICK SHALL BE PLACED BETWEEN THE SIDEWALK AND ALL STRUCTURES  
 6. EXPANSION JOINTS SHALL ALSO BE PLACED WHERE THE SIDEWALK ABUTS EXISTING SIDEWALKS AND WHERE THE SIDEWALK ABUTS A CURB

**8** EXPANSION JOINT  
 SCALE: 3"=1'-0"

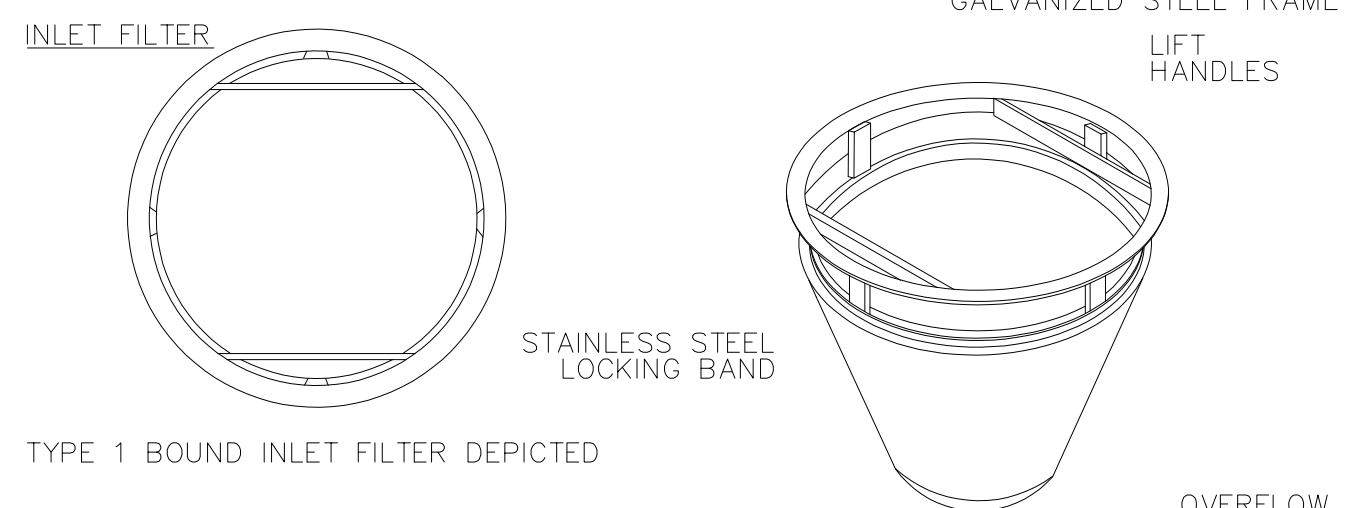

NOTE: ROUND AND SQUARE/RECTANGULAR INLET FILTERS AVAILABLE FOR MOST NEENAH AND EAST JORDAN BEEHIVE, ROLL CURB AND CURB BOX FRAME TYPES.

\*\*CERTIFICATION: ALL IPP INLET FILTERS CONFORM TO IDOT SPECIFICATIONS AS OUTLINED IN ARTICLE 1081.15 OF IDOT'S STANDARDS SPECIFICATIONS GUIDE

IDOT Std	Grate Size	Opening	Filter P/N	Aprox Dims	Notes
Type 1, 5	22.75 dia	21	2200-1	D=22	Round
Type 8	33 dia	23 (mhole)	2600-8	D=26.5	Round
Type 3, 3V	22 x 16.9	20 x 15	2116-3CB	W=21, H=16	Curb box, flap
Type 11, 11V	28.75 x 11.38	27 x 9.875	2811-11CB	W=28, H=11	Curb box, flap
Type 6	22 x 22.75	20.25 x 23+	2122-6	W=21, H=22	Rollod curb
Type 12	28.75 x 17.25	27 x 16.5+	2817-12	W=28, H=16.5	Rollod curb
Type 4	21.75 x 14.75	20 x 13	2114-4	W=21, H=14	Rect flat
Type 20, 21, 22	22.5 x 22.5	20 x 20	2222-20	W=22, H=22	Square flat
Type 23	24 x 16.25	22 x 14.5	2316-23	W=23, H=15	Rect flat
Type 24	24 x 22.5	22 x 20.5	2322-24	W=23, H=22	Rect flat

**4** TEMPORARY CONCRETE WASHOUT FACILITY - BARRIER WALL  
 SCALE: NTS

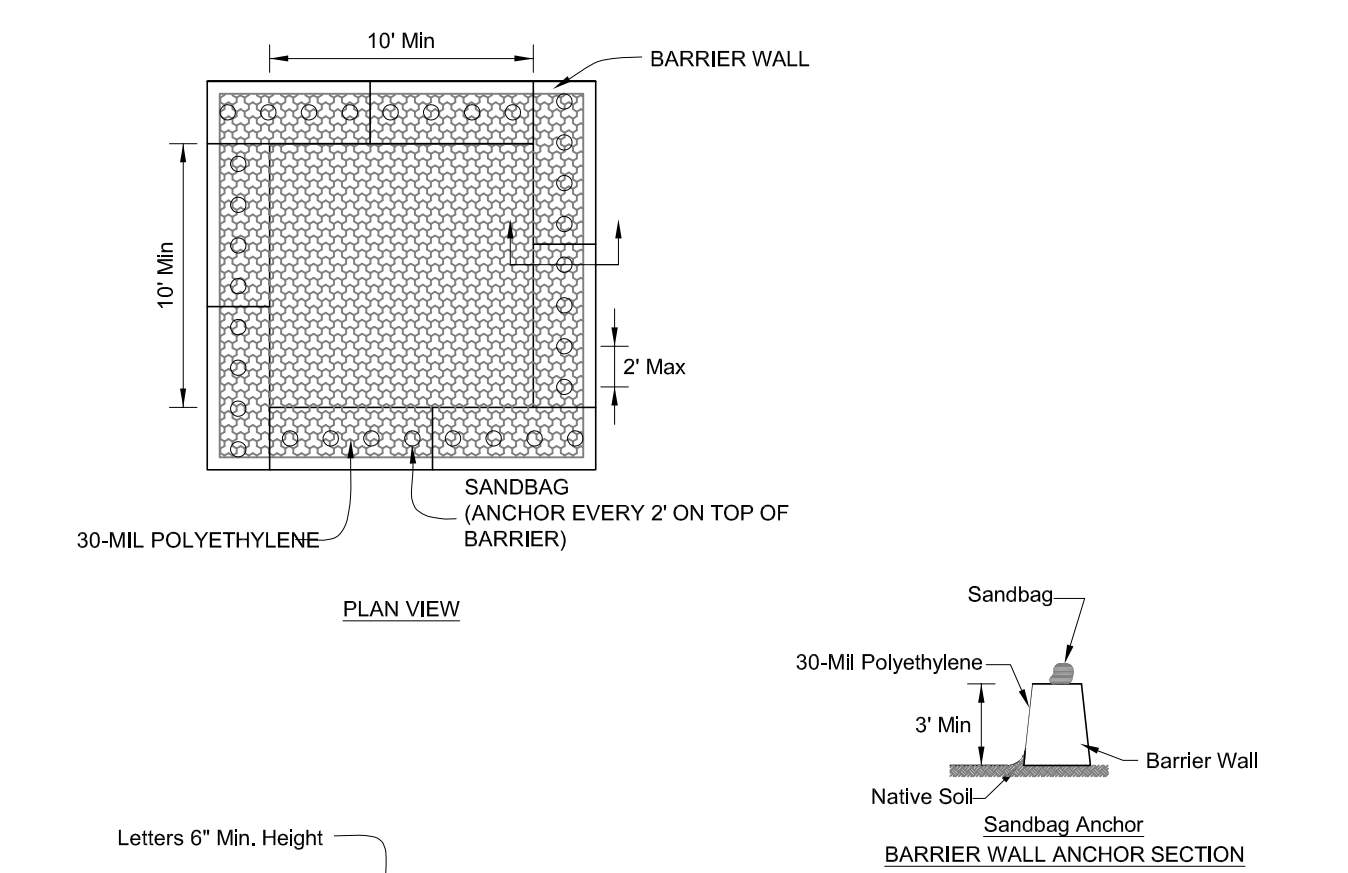

- NOTES:  
 1. Maintaining temporary concrete washout facilities shall include removing and disposing of hardened concrete and/or slurry and returning the facilities to a functional condition.  
 2. Facility shall be cleaned or reconstructed in a new area once washout becomes two-thirds full.

DESIGNED	DATE
DRAWN	DATE
CHECKED	DATE
APPROVED	DATE

TEMPORARY CONCRETE WASHOUT FACILITY - BARRIER WALL

**7** CONTROL JOINT  
 SCALE: 1"=1'-0"

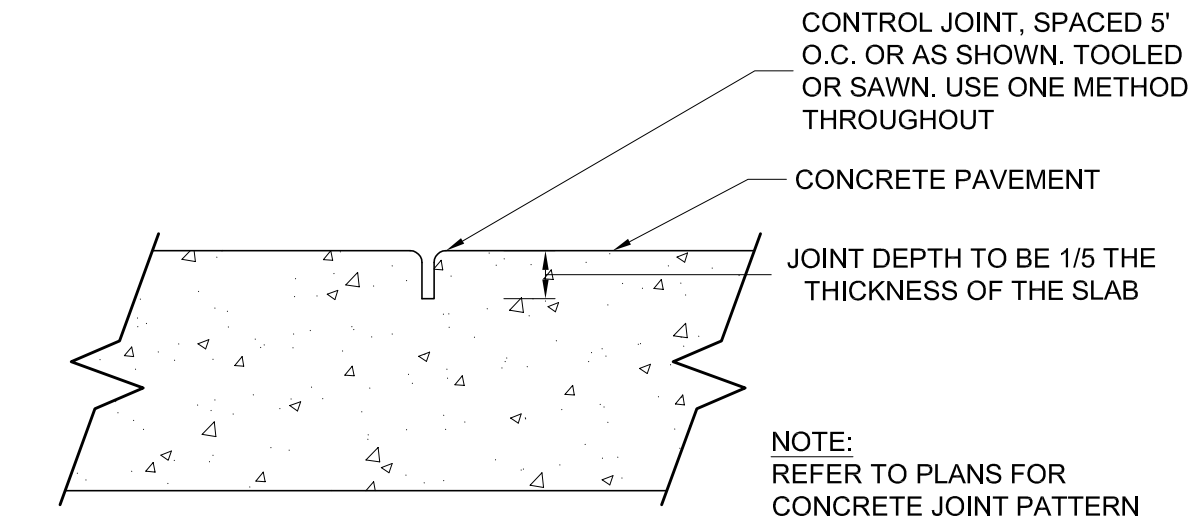

**9** PAVERS ON CONCRETE BASE  
 SCALE: 1"=1'-0"

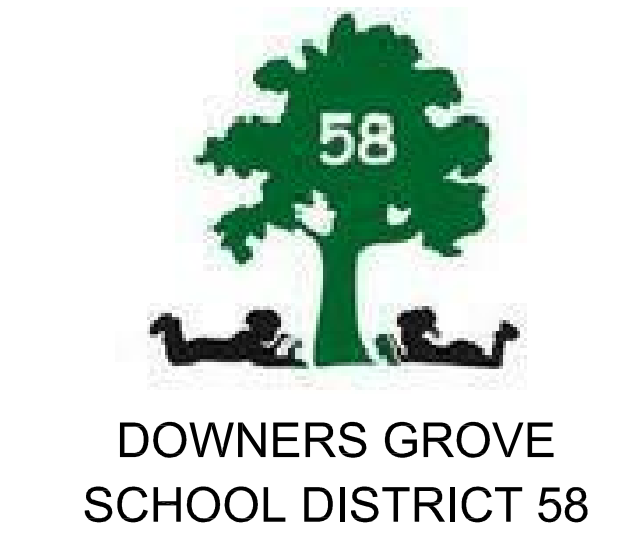
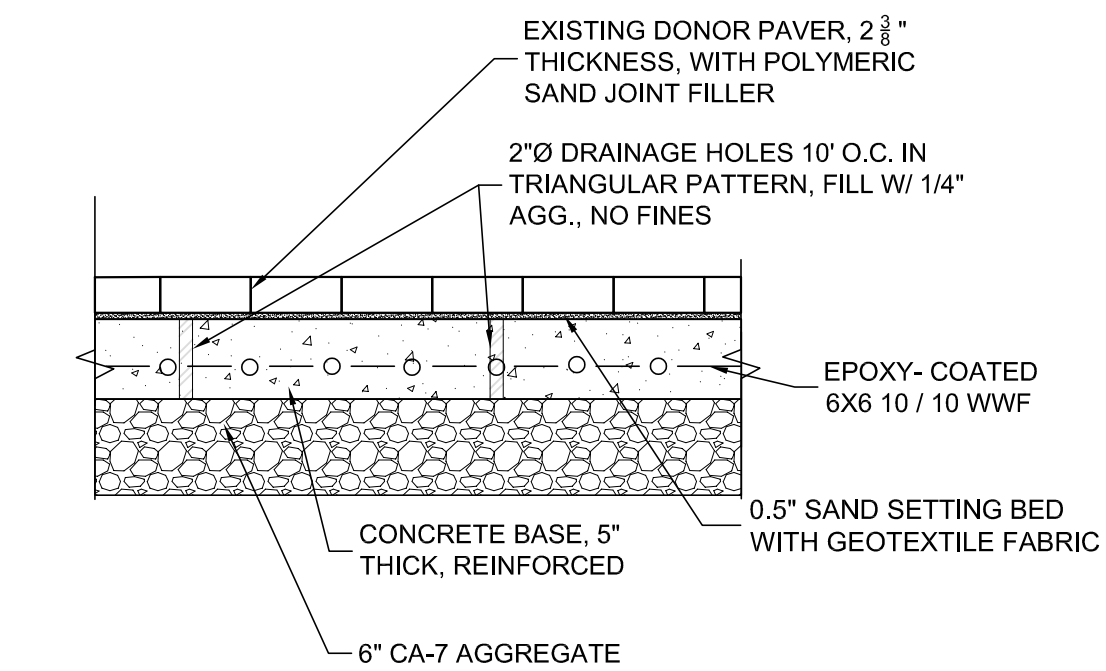

DOWNERS GROVE SCHOOL DISTRICT 58

**Wight**

Wight & Company  
 wightco.com

2500 North Frontage Road  
 Darien, IL 60561

P 630.969.7000  
 F 630.969.7979

ISSUE FOR BID	1/19/2023	
PERMIT SET	12/02/22	
REV	DESCRIPTION	DATE

**PIERCE DOWNER PLAYGROUND IMPROVEMENTS - PHASE 2**

1436 GRANT STREET  
 DOWNERS GROVE, IL 60515

**DETAILS**

Project Number:  
 210139  
 Drawn By:  
 LR  
 Sheet:

**L5.00**



S:\Darien\Downers Grove SD58\210139\_Pierce Downer Playground\01\11 Drawings\02 CD\PHASE II\210139-L5.00 DETAILS PH2.dwg kbruck Jan 19, 2023 9:50:23 am

Wight © Copyright All rights reserved. No part of these documents may be reproduced, stored, or transmitted in any form or by any means, electronic, mechanical, photocopying, recording or otherwise, without the prior written consent of Wight.

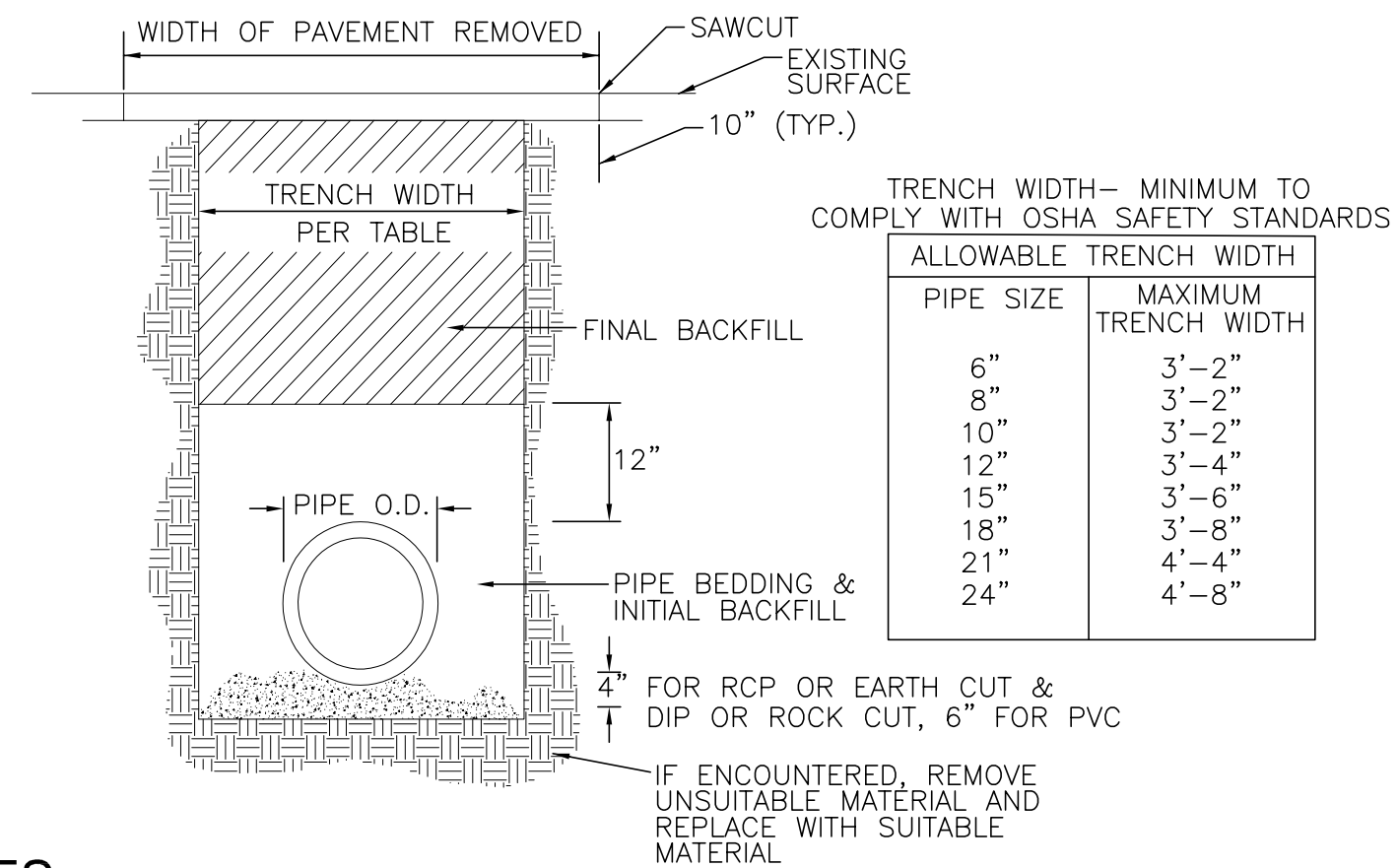

TRENCH WIDTH - MINIMUM TO COMPLY WITH OSHA SAFETY STANDARDS

PIPE SIZE	MAXIMUM TRENCH WIDTH
6"	3'-2"
8"	3'-2"
10"	3'-2"
12"	3'-4"
15"	3'-6"
18"	3'-8"
21"	4'-4"
24"	4'-8"

**NOTES:**

1. TRENCH WIDTH - MINIMUM TO COMPLY WITH OSHA SAFETY STANDARDS.
2. REINFORCING OF RESTORED PAVEMENT MUST MATCH EXISTING.
3. RESTORATION TO ORIGINAL SURFACE REQUIRED, NO CONCRETE PATCHES ON ASPHALT ROADS.
4. STREETS MUST REMAIN OPEN TO TRAFFIC WORK ON ONLY ONE HALF OF STREET ALLOWED AT A TIME.
5. CONTRACTORS SHALL ERECT AND MAINTAIN SUFFICIENT AND SUITABLE SIGNS AND BARRICADES DURING AND AFTER CONSTRUCTION.
6. STREETS SHALL BE RESTORED TO THEIR ORIGINAL CONDITION WITHIN 72 HOURS FROM THE TIME THE WORK COMMENCED. STREET OPENINGS SHALL BE BACKFILLED WITH APPROVED GRANULAR MATERIAL AND A TEMPORARY PAVEMENT SURFACE OF COMPACTED COLD ASPHALT MATERIAL SHALL BE INSTALLED WITHIN 24 HOURS FROM THE TIME THE WORK COMMENCED.
7. A MINIMUM OF 24 HOURS NOTICE MUST BE GIVEN TO THE MUNICIPALITY BEFORE BACKFILLING AND RESTORATION WORK ARE TO COMMENCE.

**PIPE BEDDING & INITIAL BACKFILL**

FOR PVC AND HDPE, CRUSHED STONE (IDOT CA-11 OR CA-13) TO 1 FOOT OVER PIPE. FOR RCP & DIP, CA-6 TO SPRING LINE. PLACE IN MAXIMUM 6" LIFTS AND COMPACTED TO 95% STANDARD PROCTOR DENSITY PER AASHTO T-99.

**FINAL BACKFILL**

IN PAVEMENT AREAS AND WHERE TRENCH FALLS WITHIN A 1 TO 1 SLOPE EXTENDED FROM THE EDGE OF THE PAVEMENT, MATERIAL SHALL BE TRENCH-BACKFILL (CA-6 PER I.D.O.T. SPECS.) COMPACTED TO 95% STANDARD PROCTOR DENSITY PER AASHTO T-99.

IN AREAS WHERE GRASS IS REMOVED AND PARKWAY RESTORATION IS REQUIRED LANDSCAPE FABRIC SHALL BE PLACED BETWEEN THE BACKFILLED MATERIAL AND THE REQUIRED TOPSOIL AS DIRECTED BY THE MUNICIPAL DIRECTOR OF PUBLIC WORKS.

IN LANDSCAPE AREAS MATERIAL SHALL BE SELECT. EXCAVATED MATERIAL, FREE OF ROCKS AND DEBRIS COMPACTED TO 85% STANDARD PROCTOR DENSITY PER AASHTO T-99.

**UTILITY CROSSINGS**

AT UTILITY CROSSINGS, INSTALL TRENCH BACKFILL, AS ABOVE, FROM THE PIPE BEDDING TO 1 FOOT OVER THE HIGHER PIPE. SUCH A GRANULAR CRADLE SHALL BE CONSTRUCTED REGARDLESS OF WHETHER THE CROSSING OCCURS IN PAVED OR LANDSCAPED AREAS.

WHERE UTILITY CROSSINGS INCLUDE A WATER MAIN, USE CLASS IV COMPACTED SELECT EXCAVATED MATERIAL BETWEEN PIPES AS REQUIRED BY THE STANDARD SPECIFICATIONS FOR SEWER & WATER MAIN CONSTRUCTION IN ILLINOIS, STANDARD DRAWINGS 19 THROUGH 24.

**1 PIPE BEDDING & BACKFILL - STORM SEWER**  
SCALE: NTS



DOWNERS GROVE  
SCHOOL DISTRICT 58

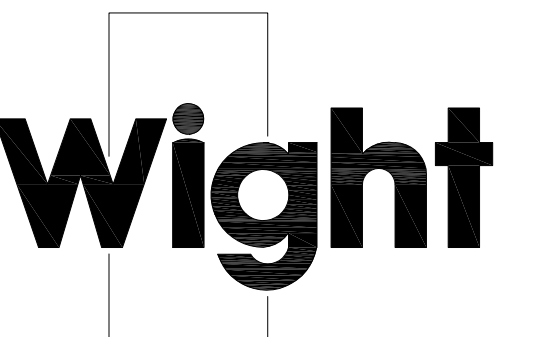

Wight & Company  
wightco.com

2500 North Frontage Road  
Darien, IL 60561

P 630.969.7000  
F 630.969.7979

ISSUE FOR BID	1/19/2023
PERMIT SET	12/02/22
REV	DESCRIPTION DATE

**PIERCE DOWNER  
PLAYGROUND  
IMPROVEMENTS -  
PHASE 2**

1436 GRANT STREET  
DOWNERS GROVE, IL 60515

**DETAILS**

Project Number:  
210139  
Drawn By:  
LR  
Sheet:

**L5.02**